

Features

- 1600UT SS is a captured outside and inside glazed or SSG verticals with captured horizontal curtain wall system
- 1600UT SS has 2-1/2" (63.5) sightline
- Standard 7-3/4" (196.9) depth system, 6-1/4" (158.8) depth system available
- Standard infill options 1" (25.4), 1-1/4" (31.8) and 1-5/16" (33.3)
- Thermally Broken
- Perimeter seals will have two lines of sealant required with optional interior seal
- 1600UT SS can be supplied fabricated and KD or in stock lengths
- Interlocking mullion design eliminates need for anti-buckling clips
- Screw Spline concealed fastener joinery creates smooth, monolithic appearance
- EPDM gaskets
- Screw spline joinery method allows shop assembly of ladder sections, reducing field labor
- Corners available
- Offers integrated entrance framing systems
- Silicone compatible glazing materials for long-lasting seals
- Two color option
- Permanodic[®] anodized finishes option
- Painted finishes in standard and custom choices

Optional Features

- Captured system with GLASSvent[®] UT Windows
- Vertical SSG system with GLASSvent[®] Windows for Curtain Wall
- Deep covers available
- Expansion Horizontal
- Profit\$Maker[®] Plus die sets available

Product Applications

- Ideal for low to mid-rise applications where high performance is desired
- Most of the product assembly can be done in the shop rather than the field. This allows for better quality control and reduces expensive field labor.

For specific product applications,
consult your Kawneer representative.

Laws and building and safety codes governing the design and use of Kawneer products, such as glazed entrance, window, and curtain wall products, vary widely. Kawneer does not control the selection of product configurations, operating hardware, or glazing materials, and assumes no responsibility therefor.

Kawneer reserves the right to change configuration without prior notice when deemed necessary for product improvement.
© 2024, Kawneer Company, Inc.

Architects - Most extrusion and window types illustrated in this catalog are standard products for Kawneer. These concepts have been expanded and modified to afford you design freedom. Some miscellaneous details are non-standard and are intended to demonstrate how the system can be modified to expand design flexibility. Please contact your Kawneer representative for further assistance.

PICTORIAL VIEW5

CAPTURED MULLION FRAMING DETAILS (OUTSIDE GLAZED).....6, 8

VERTICAL SSG MULLION FRAMING DETAILS (OUTSIDE GLAZED)..... 9, 11

CAPTURED MULLION FRAMING (INSIDE GLAZED)12, 13

ENTRANCE DETAILS14, 15

CORNER DETAILS.....16, 17

GLASSvent® UT WINDOWS 18

GLASSvent® WINDOWS FOR CURTAIN WALL 18

VAPOR BARRIER DETAILS19

ANCHORING20, 22

WIND LOAD / DEAD LOAD CHARTS23-43

THERMAL CHARTS44-57

Metric (SI) conversion figures are included throughout these details for reference. Numbers in parentheses () are millimeters unless otherwise noted.

The following metric (SI) units are found in these details:

- m – meter
- cm – centimeter
- mm – millimeter
- s – second
- Pa – pascal
- MPa – megapascal

Laws and building and safety codes governing the design and use of Kawneer products, such as glazed entrance, window, and curtain wall products, vary widely. Kawneer does not control the selection of product configurations, operating hardware, or glazing materials, and assumes no responsibility therefor.

Kawneer reserves the right to change configuration without prior notice when deemed necessary for product improvement.
© 2024, Kawneer Company, Inc.

Laws and building and safety codes governing the design and use of Kawneer products, such as glazed entrance, window, and curtain wall products, vary widely. Kawneer does not control the selection of product configurations, operating hardware, or glazing materials, and assumes no responsibility therefor.

Kawneer reserves the right to change configuration without prior notice when deemed necessary for product improvement.
© 2024, Kawneer Company, Inc.

Laws and building and safety codes governing the design and use of Kawneer products, such as glazed entrance, window, and curtain wall products, vary widely. Kawneer does not control the selection of product configurations, operating hardware, or glazing materials, and assumes no responsibility therefor.

Kawneer reserves the right to change configuration without prior notice when deemed necessary for product improvement.
© 2024, Kawneer Company, Inc.

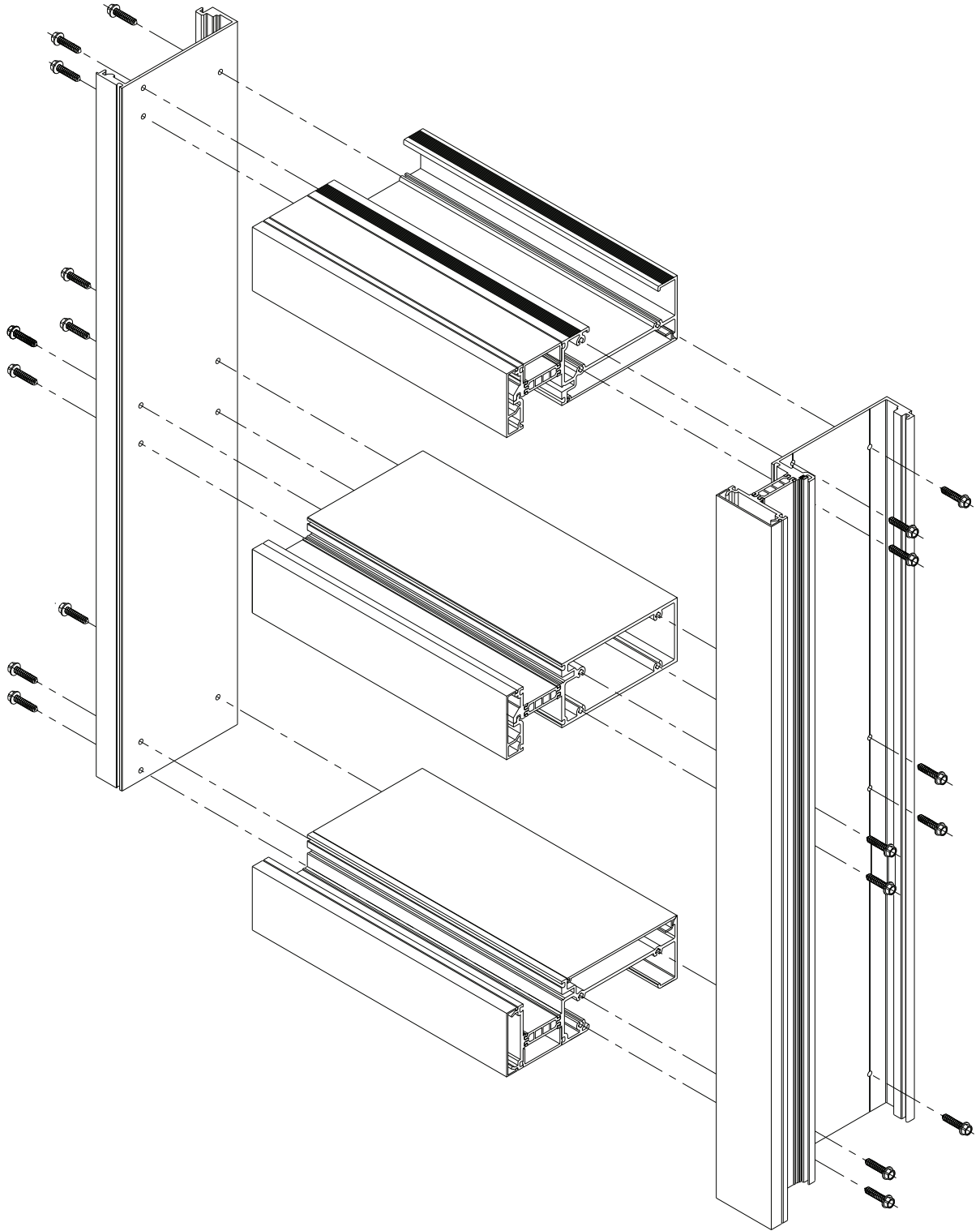

Additional information and CAD details are available at www.kawneer.com

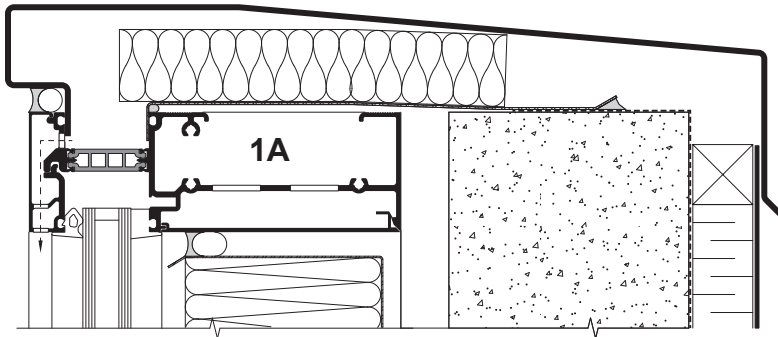

OPTIONAL HEAD THAT ALLOWS PARAPET FLASHING ATTACHED
NOTE: 7-3/4" SYSTEM SHOWN, 6-1/4" SYSTEM SIMILAR

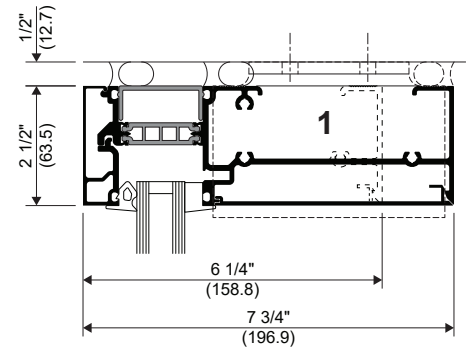

HEAD

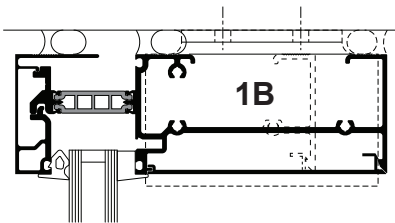

OPTIONAL HEAD WITH SNAP-ON PERIMETER COVER

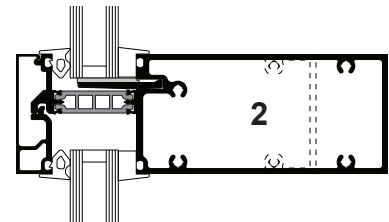

HORIZONTAL

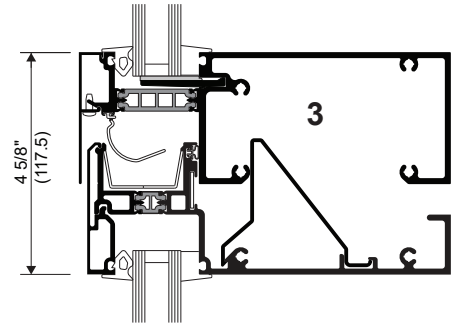

EXPANSION HORIZONTAL
NOTE: 7-3/4" SYSTEM SHOWN,
6-1/4" SYSTEM SIMILAR

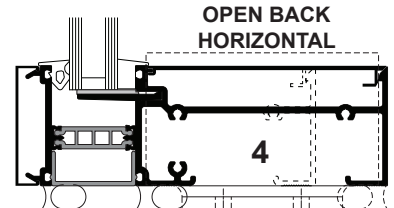

OPEN BACK HORIZONTAL

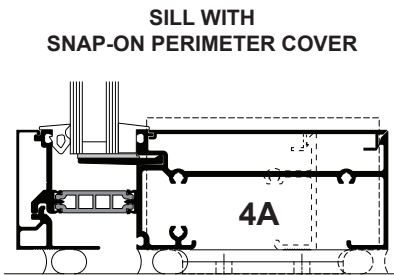

SILL WITH SNAP-ON PERIMETER COVER

OPTIONAL SILL WITH SNAP-ON PERIMETER COVER

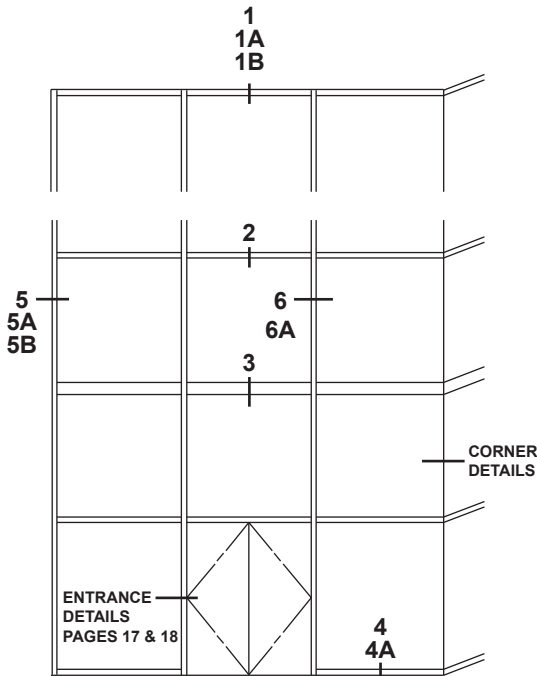

ELEVATION IS NUMBER KEYED TO DETAILS
1", 1-1/4" OR 1-5/16" INFILL AVAILABLE

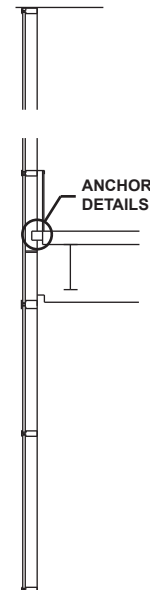

ANCHOR DETAILS

Laws and building and safety codes governing the design and use of Kawneer products, such as glazed entrance, window, and curtain wall products, vary widely. Kawneer does not control the selection of product configurations, operating hardware, or glazing materials, and assumes no responsibility therefor.

Kawneer reserves the right to change configuration without prior notice when deemed necessary for product improvement.

© 2024, Kawneer Company, Inc.

JAMB OPTIONS

VERTICAL OPTIONS

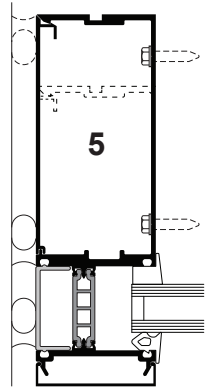

JAMB WITH SNAP-ON COVER (Standard)

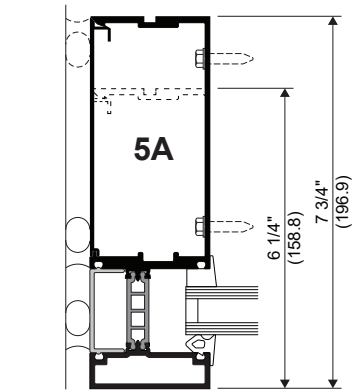

JAMB WITH HOLLOW PRESSURE PLATE (Optional)

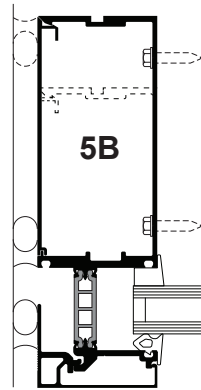

JAMB WITH SNAP-ON PERIMETER COVER (Optional)

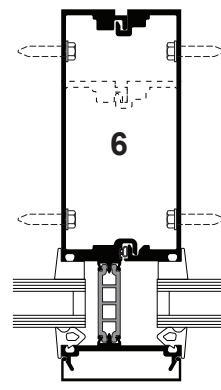

VERTICAL WITH SNAP-ON COVER (Standard)

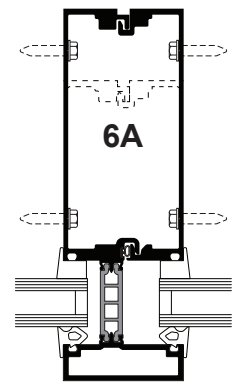

VERTICAL WITH HOLLOW PRESSURE PLATE (Optional)

OPTIONAL 2-1/2" (63.5) DEEP COVER

NOTE: DEEP COVER IS NOT APPLICABLE WITH HORIZONTALS (OUTSIDE GLAZING)

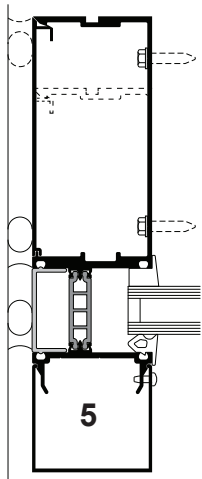

JAMB

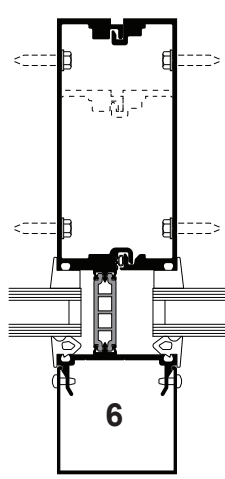

VERTICAL

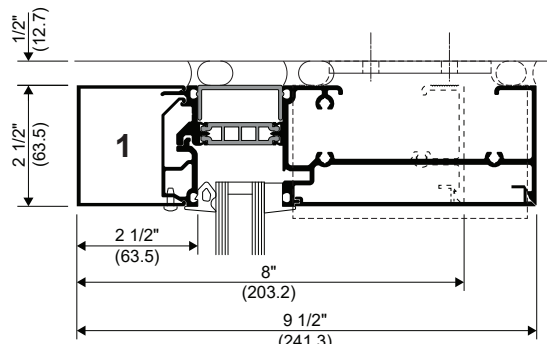

HEAD

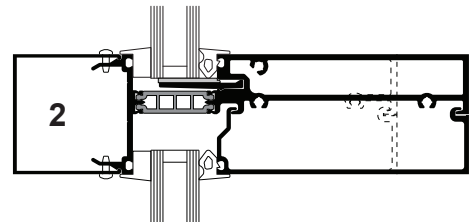

HORIZONTAL

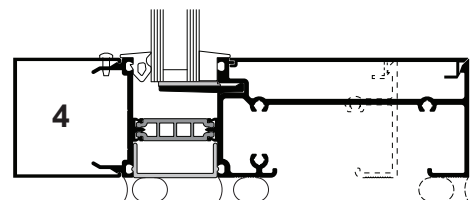

SILL

Laws and building and safety codes governing the design and use of Kawneer products, such as glazed entrance, window, and curtain wall products, vary widely. Kawneer does not control the selection of product configurations, operating hardware, or glazing materials, and assumes no responsibility therefor.

Kawneer reserves the right to change configuration without prior notice when deemed necessary for product improvement.
© 2024, Kawneer Company, Inc.

Additional information and CAD details are available at www.kawneer.com

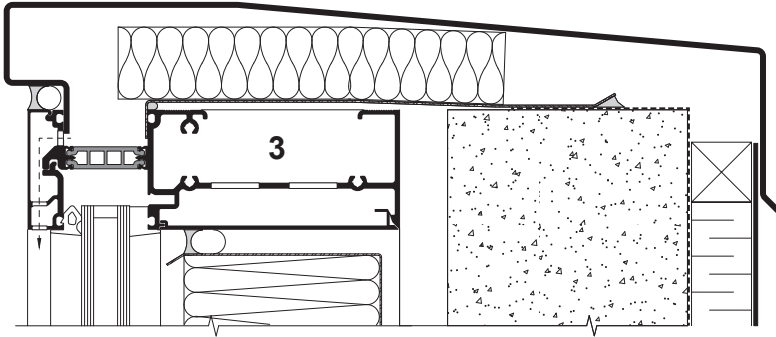

OPTIONAL HEAD THAT ALLOWS PARAPET FLASHING ATTACHED
NOTE: 7-3/4" SYSTEM SHOWN, 6-1/4" SYSTEM SIMILAR

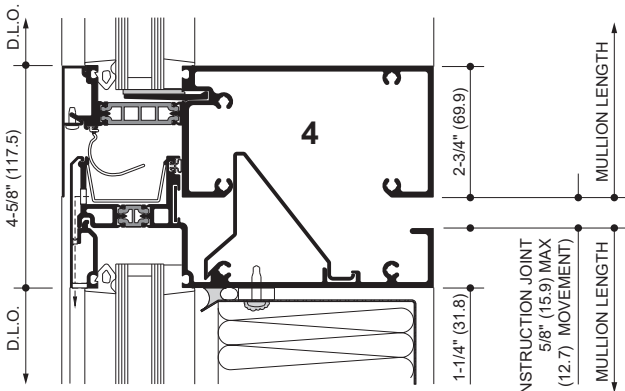

EXPANSION JOINT

CONSTRUCTION JOINT
5/8" (15.9) MAX
MOVEMENT
(ALLOWS +/-1/2" (12.7) MOVEMENT)

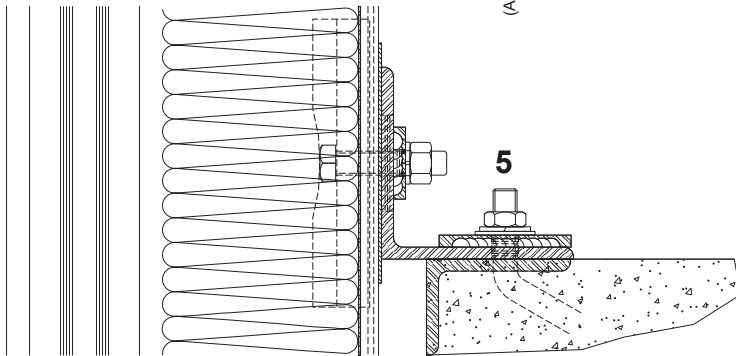

TYPICAL DEADLOAD ANCHOR

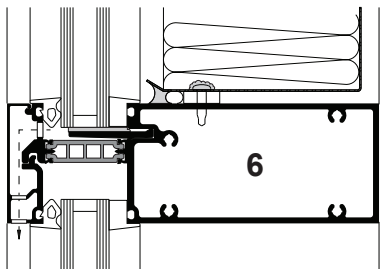

TRANSOM - SPANDREL OVER VISION

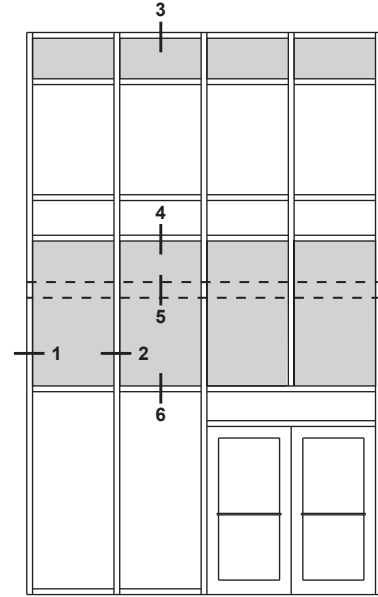

ELEVATION IS NUMBER KEYED TO DETAILS

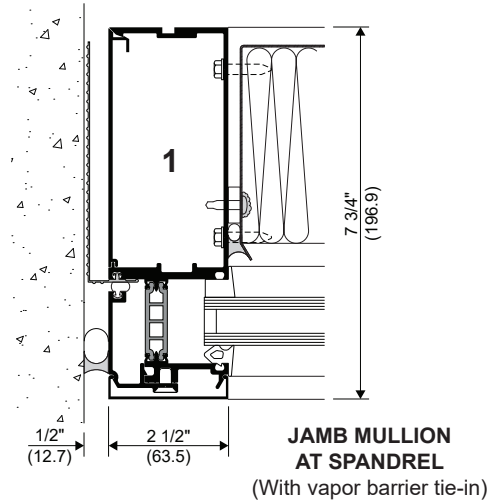

JAMB MULLION AT SPANDREL
(With vapor barrier tie-in)

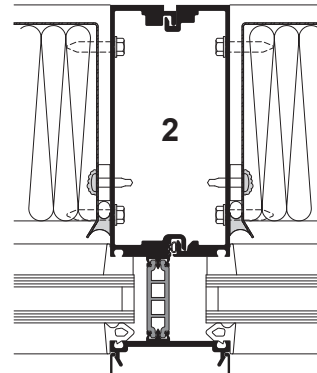

MULLION AT SPANDREL

Laws and building and safety codes governing the design and use of Kawneer products, such as glazed entrance, window, and curtain wall products, vary widely. Kawneer does not control the selection of product configurations, operating hardware, or glazing materials, and assumes no responsibility therefor.

Kawneer reserves the right to change configuration without prior notice when deemed necessary for product improvement.
© 2024, Kawneer Company, Inc.

Additional information and CAD details are available at www.kawneer.com

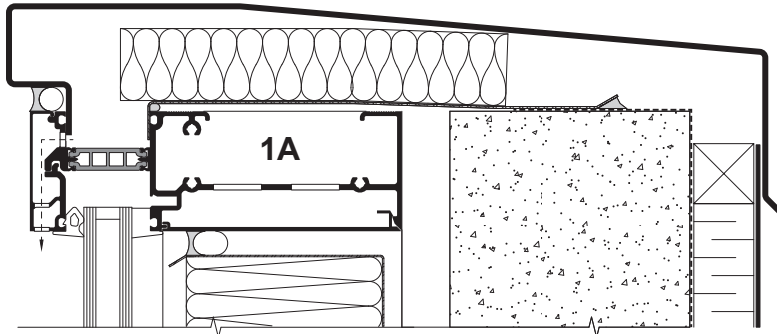

OPTIONAL HEAD THAT ALLOWS PARAPET FLASHING ATTACHED
NOTE: 7-3/4" SYSTEM SHOWN, 6-1/4" SYSTEM SIMILAR

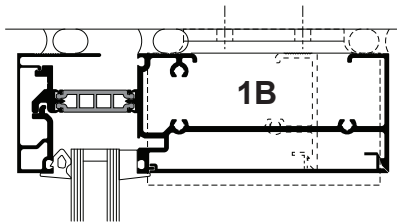

OPTIONAL HEAD WITH SNAP-ON PERIMETER COVER

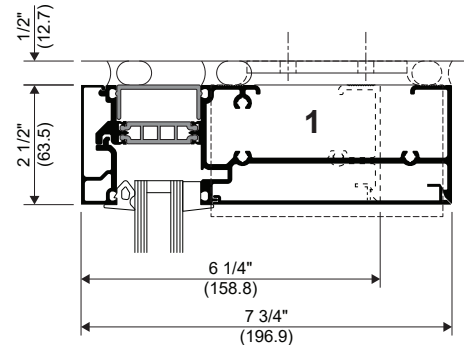

HEAD

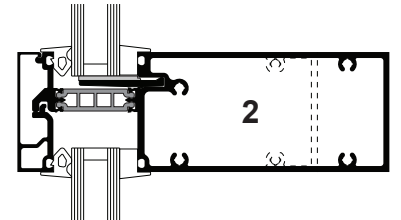

HORIZONTAL

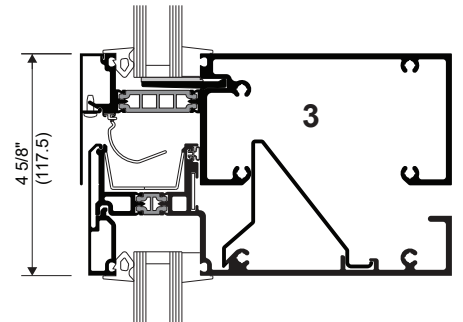

EXPANSION HORIZONTAL
NOTE: 7-3/4" SYSTEM SHOWN,
6-1/4" SYSTEM SIMILAR

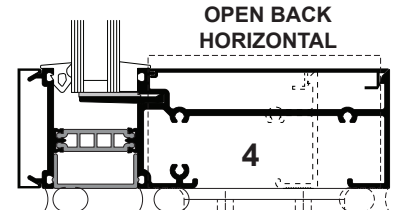

SLL

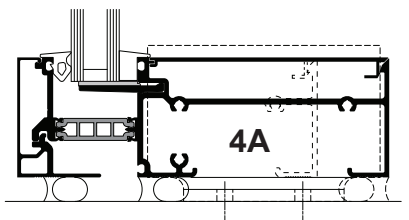

OPTIONAL SILL WITH SNAP-ON PERIMETER COVER

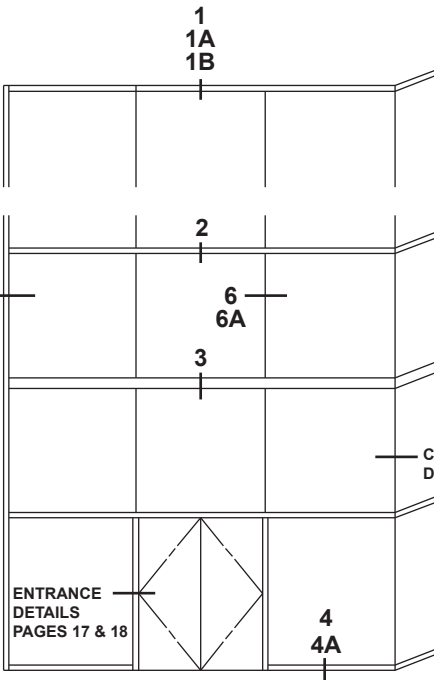

ELEVATION IS NUMBER KEYED TO DETAILS

1", 1-1/4" OR 1-5/16" INFILL AVAILABLE

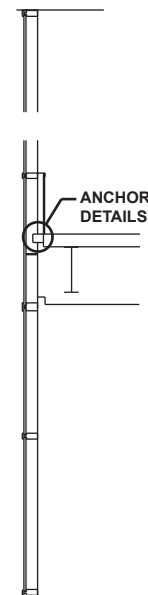

Laws and building and safety codes governing the design and use of Kawneer products, such as glazed entrance, window, and curtain wall products, vary widely. Kawneer does not control the selection of product configurations, operating hardware, or glazing materials, and assumes no responsibility therefor.

Kawneer reserves the right to change configuration without prior notice when deemed necessary for product improvement.
© 2024, Kawneer Company, Inc.

JAMB OPTIONS

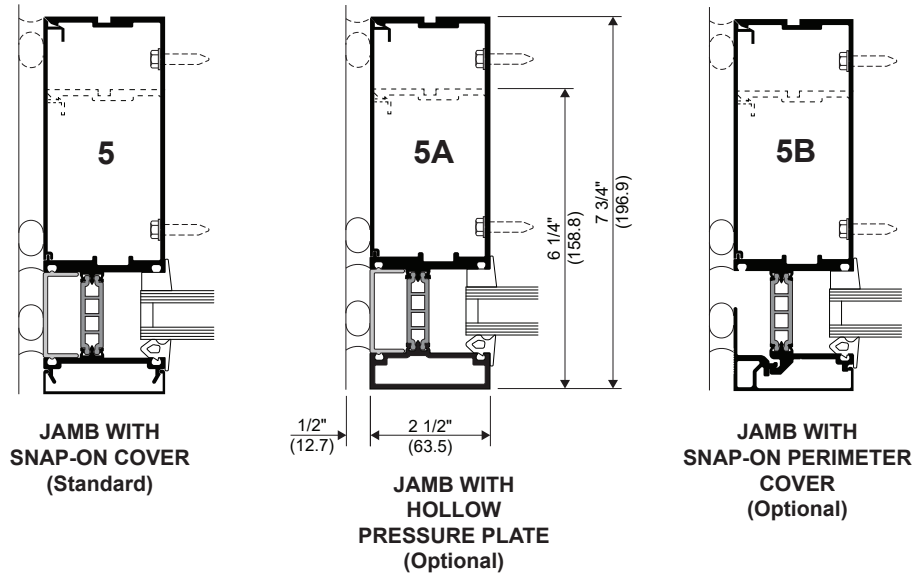

SSG VERTICAL OPTIONS

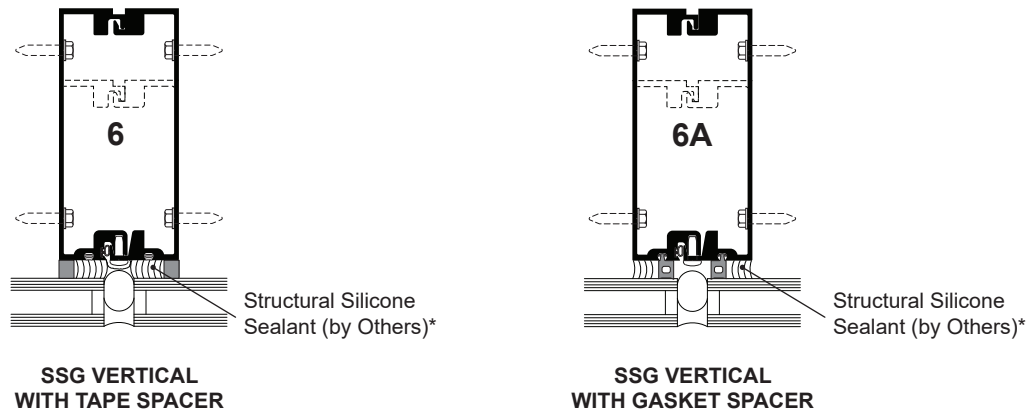

* INSTALLER NOTE: Installer is responsible for all required compatibility review and approvals with the Structural Silicone Manufacturer and the Insulating Glass Unit Manufacturer.

Additional information and CAD details are available at www.kawneer.com

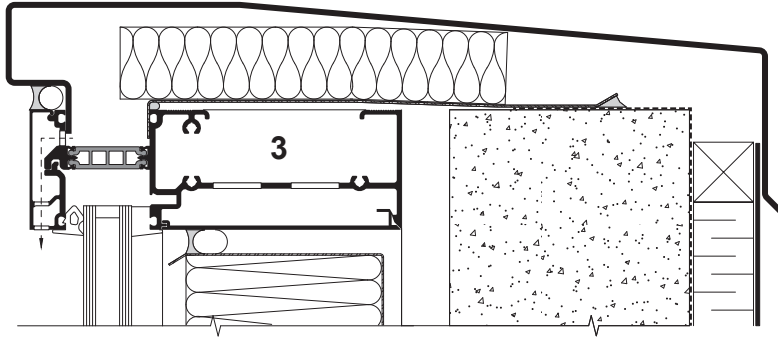

OPTIONAL HEAD THAT ALLOWS PARAPET FLASHING ATTACHED
NOTE: 7-3/4" SYSTEM SHOWN, 6-1/4" SYSTEM SIMILAR

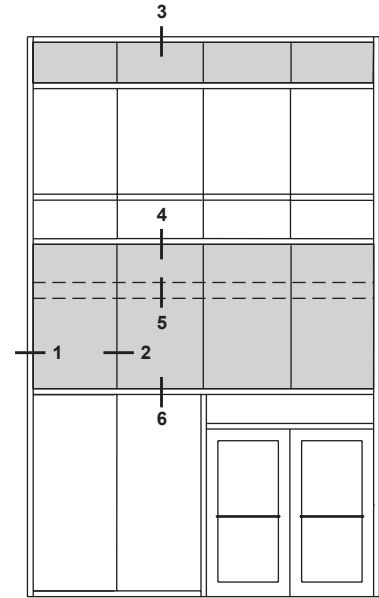

ELEVATION IS NUMBER KEYED TO DETAILS

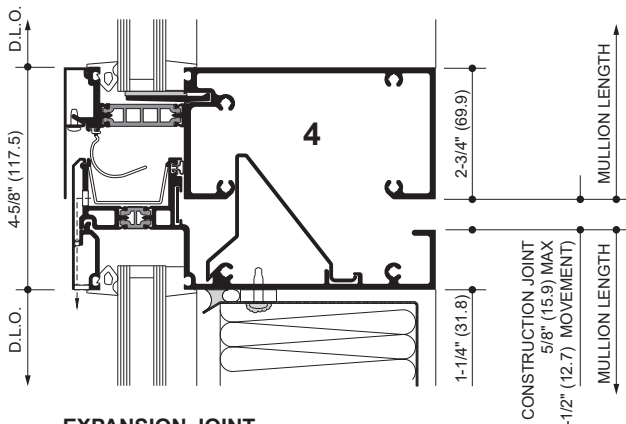

EXPANSION JOINT

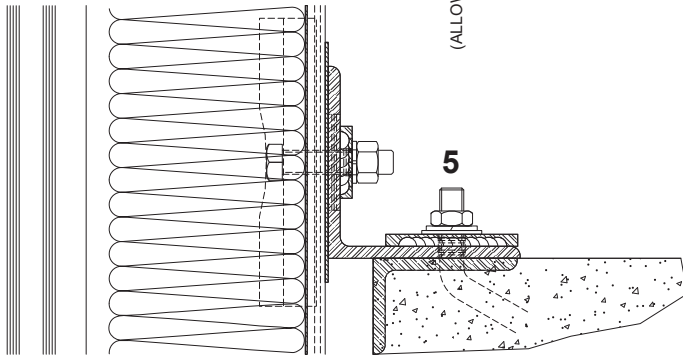

TYPICAL DEADLOAD ANCHOR

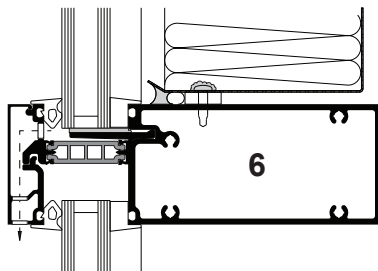

TRANSOM - SPANDREL OVER VISION

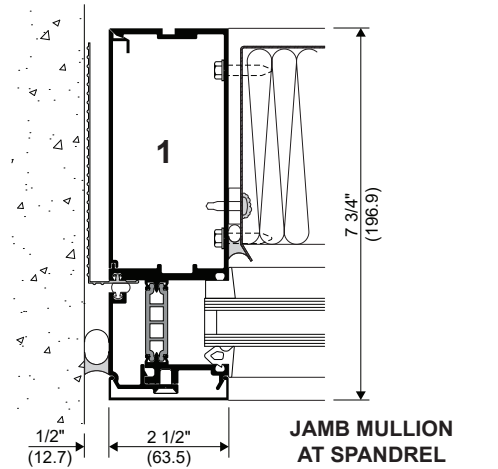

JAMB MULLION AT SPANDREL
(With vapor barrier tie-in)

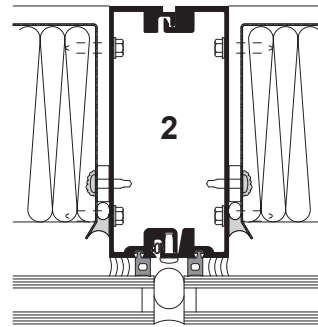

MULLION AT SPANDREL

* **INSTALLER NOTE:** Installer is responsible for all required compatibility review and approvals with the Structural Silicone Manufacturer and the Insulating Glass Unit Manufacturer.

Kawneer reserves the right to change configuration without prior notice when deemed necessary for product improvement.
© 2024, Kawneer Company, Inc.

Laws and building and safety codes governing the design and use of Kawneer products, such as glazed entrance, window, and curtain wall products, vary widely. Kawneer does not control the selection of product configurations, operating hardware, or glazing materials, and assumes no responsibility therefor.

Additional information and CAD details are available at www.kawneer.com

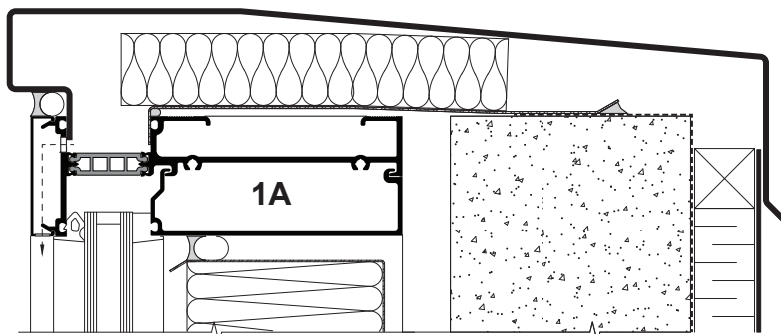

OPTIONAL HEAD THAT ALLOWS PARAPET FLASHING ATTACHED

NOTE: 7-3/4" SYSTEM SHOWN, 6-1/4" SYSTEM SIMILAR

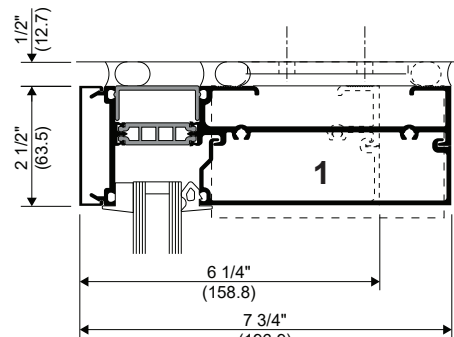

HEAD

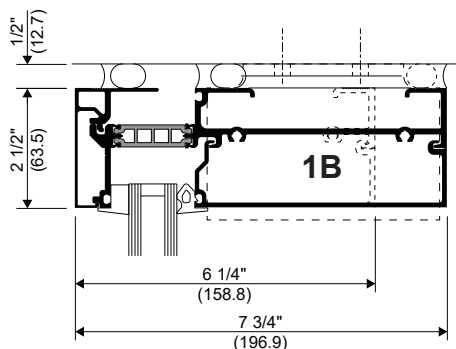

OPTIONAL HEAD WITH SNAP-ON PERIMETER COVER

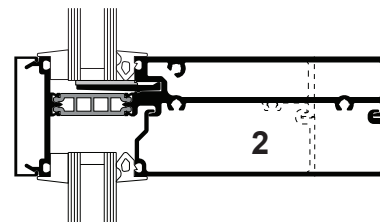

HORIZONTAL

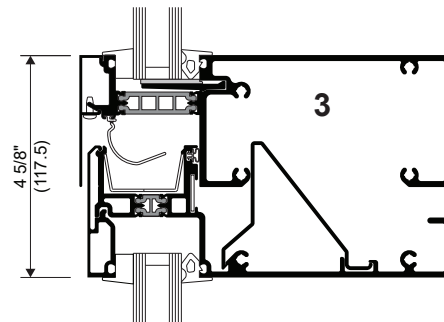

EXPANSION HORIZONTAL
NOTE: 7-3/4" SYSTEM SHOWN,
6-1/4" SYSTEM SIMILAR

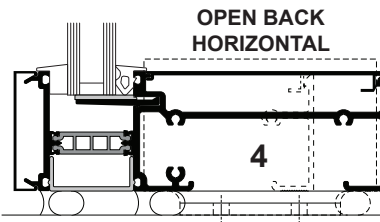

SILL

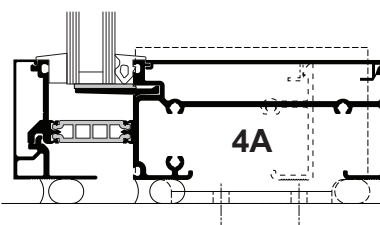

OPTIONAL SILL WITH SNAP-ON PERIMETER COVER

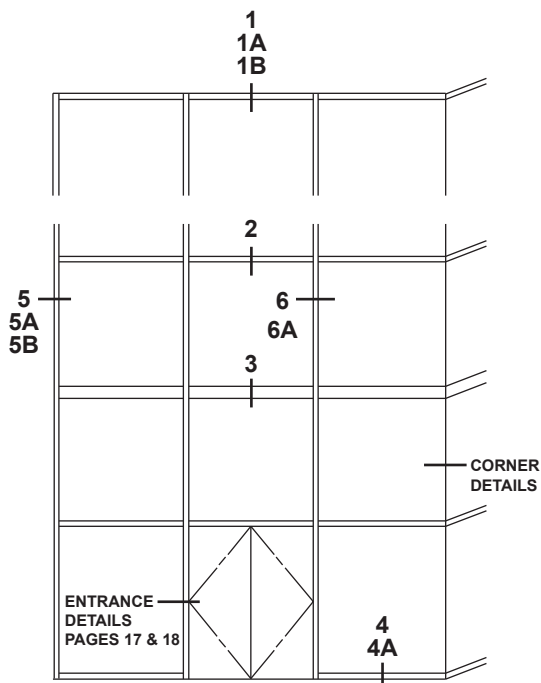

ELEVATION IS NUMBER KEYED TO DETAILS

1", 1-1/4" OR 1-5/16" INFILL AVAILABLE

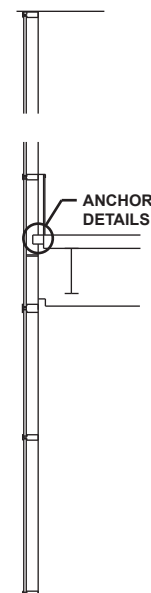

ANCHOR DETAILS

Laws and building and safety codes governing the design and use of Kawneer products, such as glazed entrance, window, and curtain wall products, vary widely. Kawneer does not control the selection of product configurations, operating hardware, or glazing materials, and assumes no responsibility therefor.

Kawneer reserves the right to change configuration without prior notice when deemed necessary for product improvement.
© 2024, Kawneer Company, Inc.

JAMB OPTIONS

VERTICAL OPTIONS

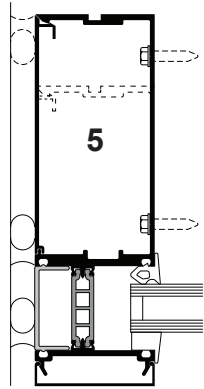

JAMB WITH SNAP-ON COVER (Standard)

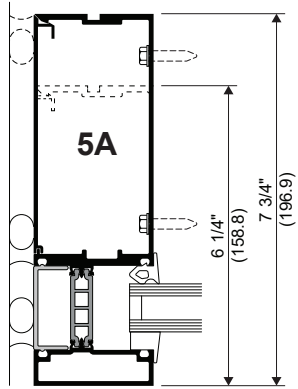

JAMB WITH HOLLOW PRESSURE PLATE (Optional)

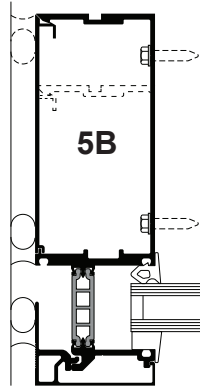

JAMB WITH SNAP-ON PERIMETER COVER (Optional)

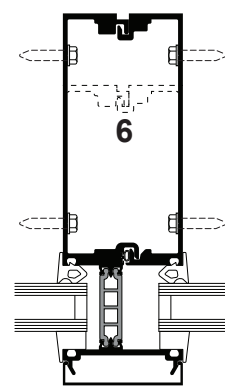

VERTICAL WITH SNAP-ON COVER (Standard)

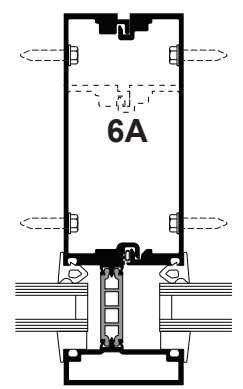

VERTICAL WITH HOLLOW PRESSURE PLATE (Optional)

OPTIONAL 2-1/2" (63.5) DEEP COVER

NOTE: DEEP COVER IS NOT APPLICABLE WITH HORIZONTALS (OUTSIDE GAZING)

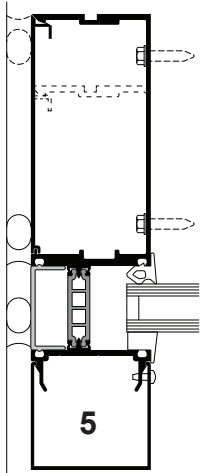

JAMB

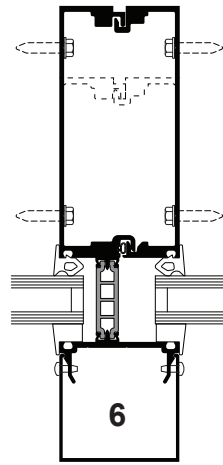

VERTICAL

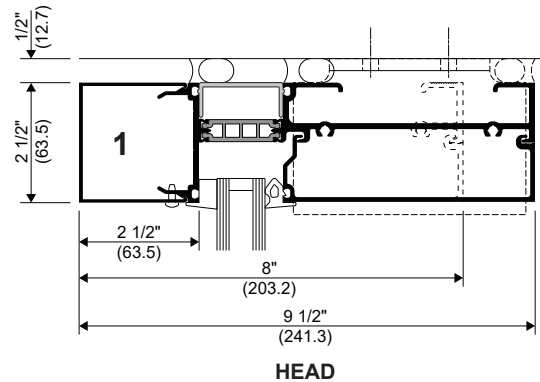

HEAD

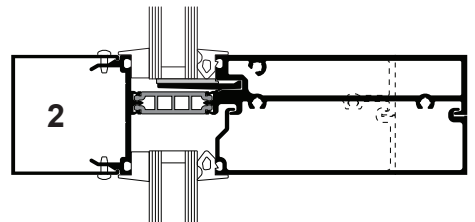

HORIZONTAL

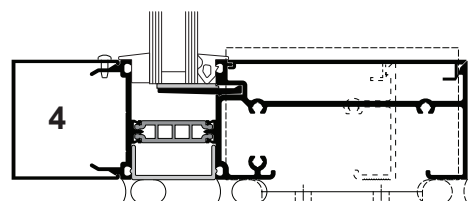

SILL

Laws and building and safety codes governing the design and use of Kawneer products, such as glazed entrance, window, and curtain wall products, vary widely. Kawneer does not control the selection of product configurations, operating hardware, or glazing materials, and assumes no responsibility therefor.

Kawneer reserves the right to change configuration without prior notice when deemed necessary for product improvement.
© 2024, Kawneer Company, Inc.

Additional information and CAD details are available at www.kawneer.com

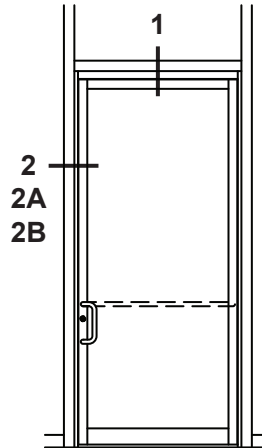

ELEVATION IS NUMBER KEYED TO DETAILS

NOTE: 250T INSULPOUR® THERMAL ENTRANCE SHOWN. OTHER TYPES OF KAWNEER DOORS MAY BE USED WITH THIS FRAMING SYSTEM. SEE ENTRANCE SECTION FOR ADDITIONAL INFORMATION.

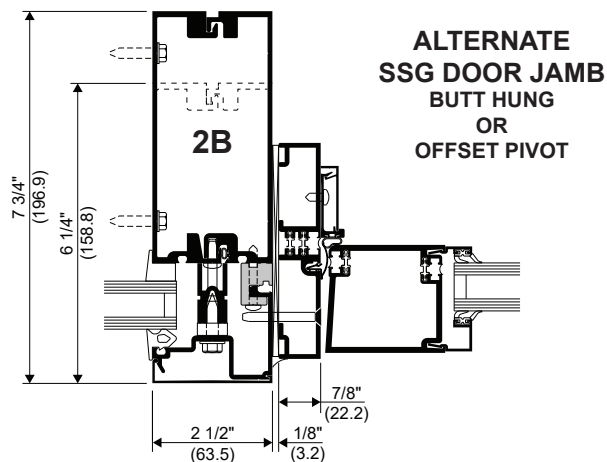
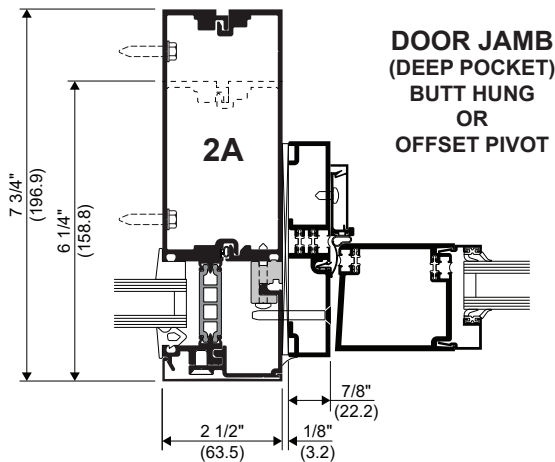
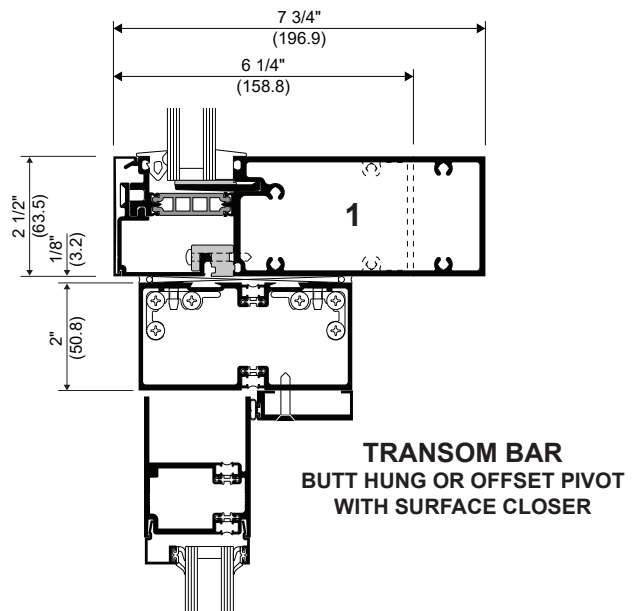
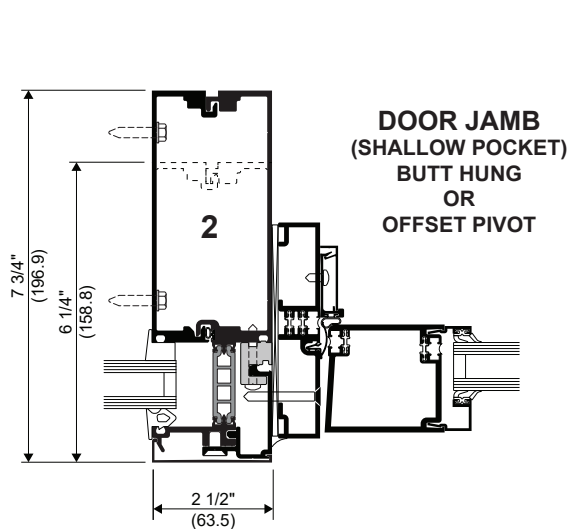

Laws and building and safety codes governing the design and use of Kawneer products, such as glazed entrance, window, and curtain wall products, vary widely. Kawneer does not control the selection of product configurations, operating hardware, or glazing materials, and assumes no responsibility therefor.

Kawneer reserves the right to change configuration without prior notice when deemed necessary for product improvement.
© 2024, Kawneer Company, Inc.

Additional information and CAD details are available at www.kawneer.com

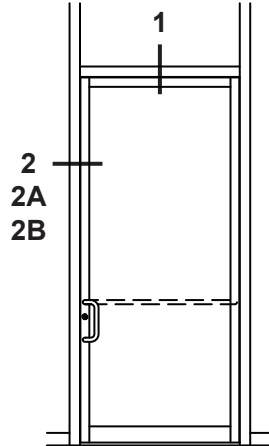

ELEVATION IS NUMBER KEYED TO DETAILS

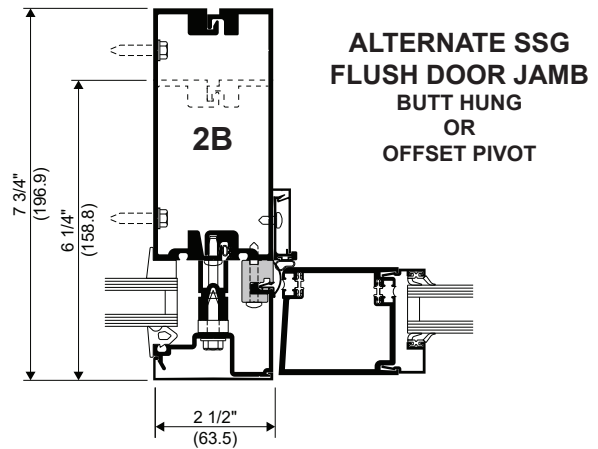
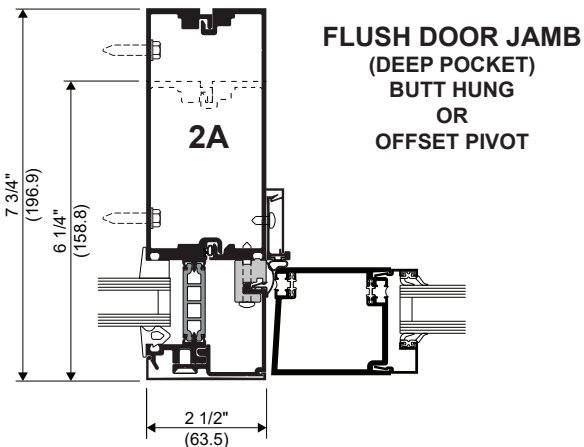
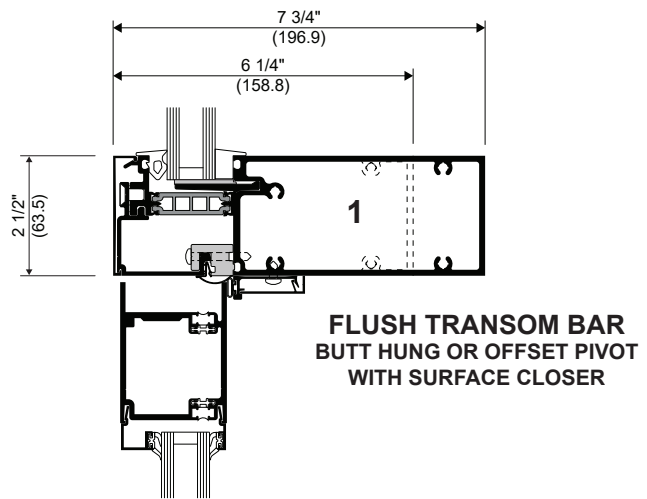
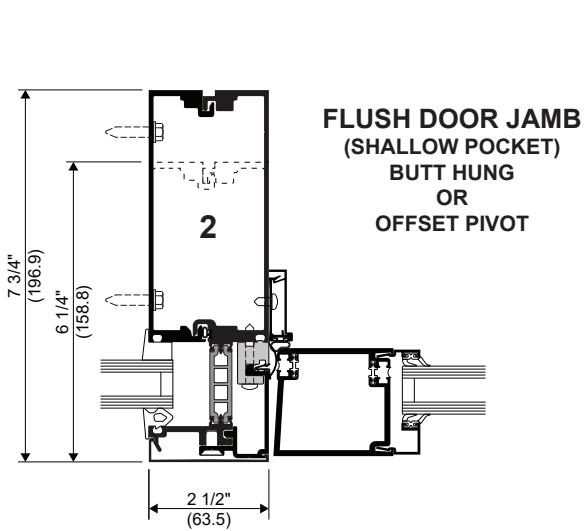

Laws and building and safety codes governing the design and use of Kawneer products, such as glazed entrance, window, and curtain wall products, vary widely. Kawneer does not control the selection of product configurations, operating hardware, or glazing materials, and assumes no responsibility therefor.

Kawneer reserves the right to change configuration without prior notice when deemed necessary for product improvement.
© 2024, Kawneer Company, Inc.

Additional information and CAD details are available at www.kawneer.com

NOTE: 7-3/4" SYSTEM SHOWN, 6-1/4" SYSTEM SIMILAR

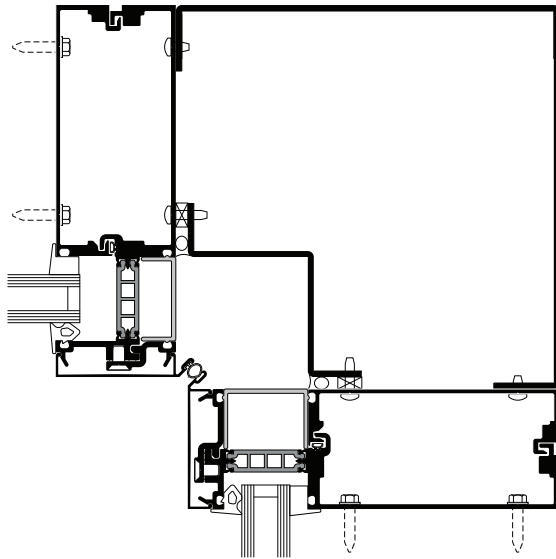

90° INSIDE CORNER

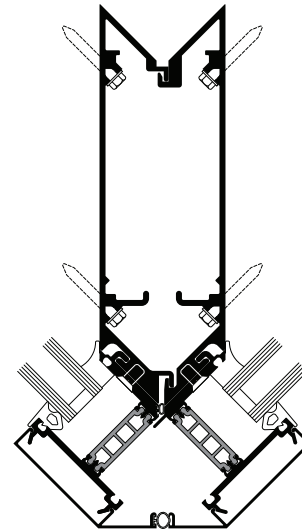

90° OUTSIDE DART CORNER

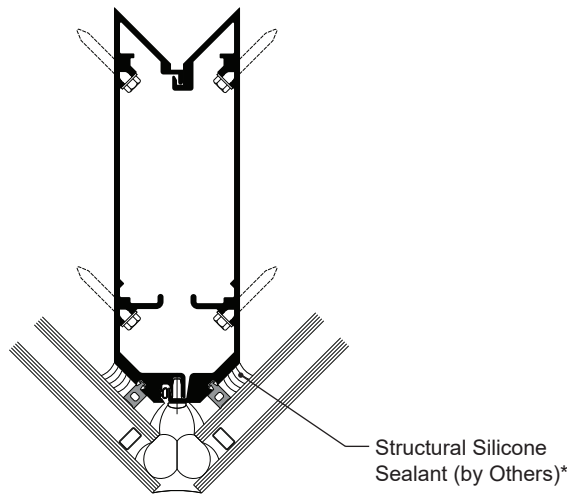

90° OUTSIDE SSG CORNER

* INSTALLER NOTE: Installer is responsible for all required compatibility review and approvals with the Structural Silicone Manufacturer and the Insulating Glass Unit Manufacturer.

Laws and building and safety codes governing the design and use of Kawneer products, such as glazed entrance, window, and curtain wall products, vary widely. Kawneer does not control the selection of product configurations, operating hardware, or glazing materials, and assumes no responsibility therefor.

Kawneer reserves the right to change configuration without prior notice when deemed necessary for product improvement.
© 2024, Kawneer Company, Inc.

Additional information and CAD details are available at www.kawneer.com

NOTE: 7-3/4" SYSTEM SHOWN, 6-1/4" SYSTEM SIMILAR

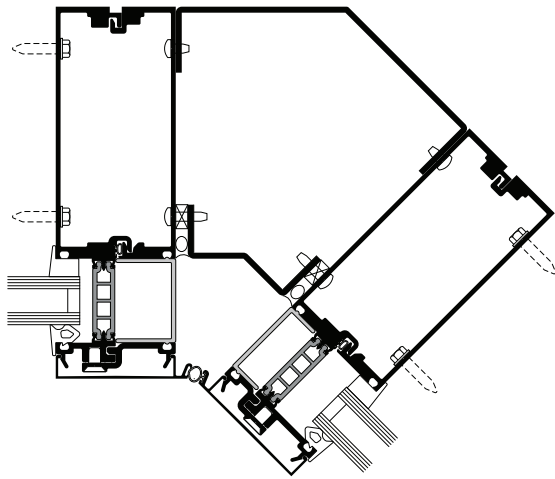

**135° INSIDE CORNER
WITHOUT EXPANSION HORIZONTAL**

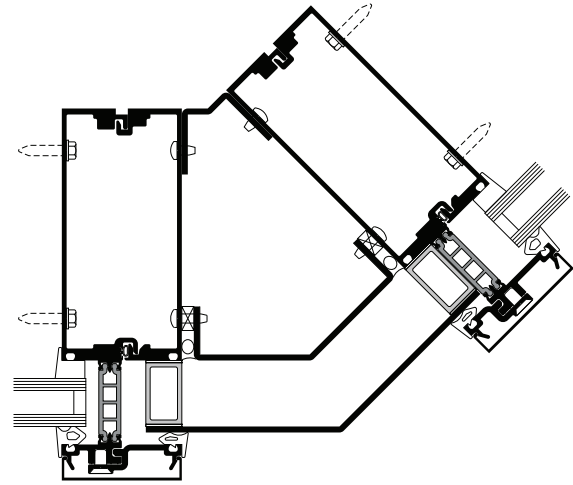

**135° OUTSIDE CORNER
WITHOUT EXPANSION HORIZONTAL**

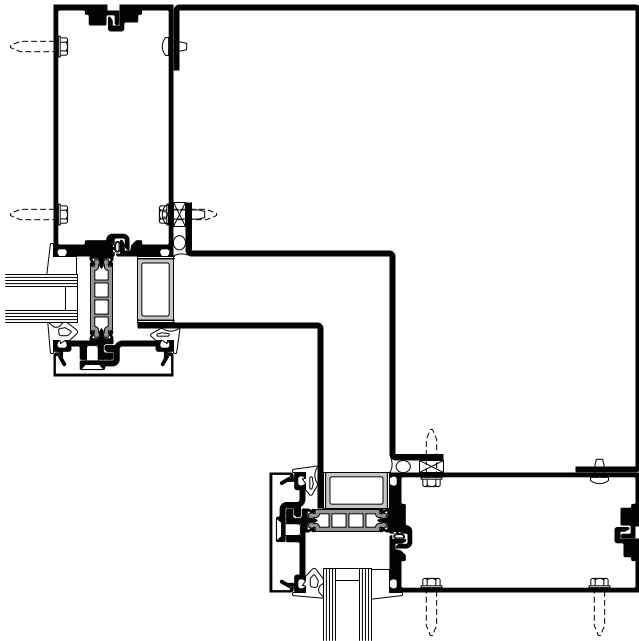

**90° INSIDE CORNER
WITH EXPANSION HORIZONTAL**

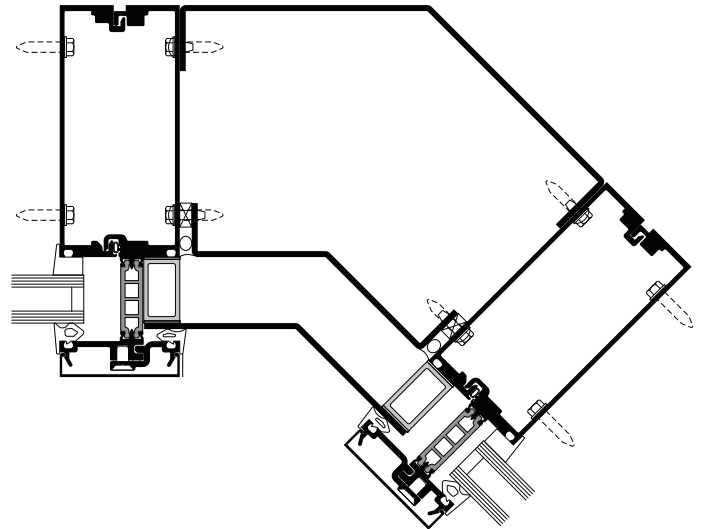

**135° INSIDE CORNER
WITH EXPANSION HORIZONTAL**

Laws and building and safety codes governing the design and use of Kawneer products, such as glazed entrance, window, and curtain wall products, vary widely. Kawneer does not control the selection of product configurations, operating hardware, or glazing materials, and assumes no responsibility therefor.

Kawneer reserves the right to change configuration without prior notice when deemed necessary for product improvement.
© 2024, Kawneer Company, Inc.

Additional information and CAD details are available at www.kawneer.com

1600UT SS Captured with GLASSvent® UT Window

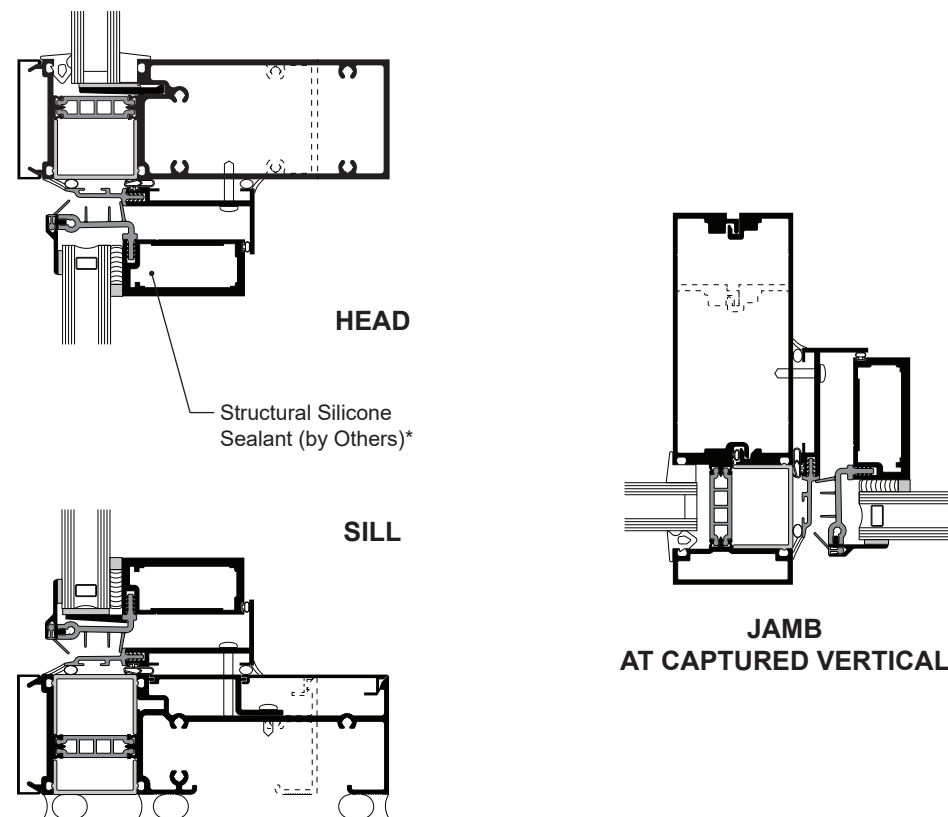

1600UT SS SSG with GLASSvent® Window for Curtain Wall

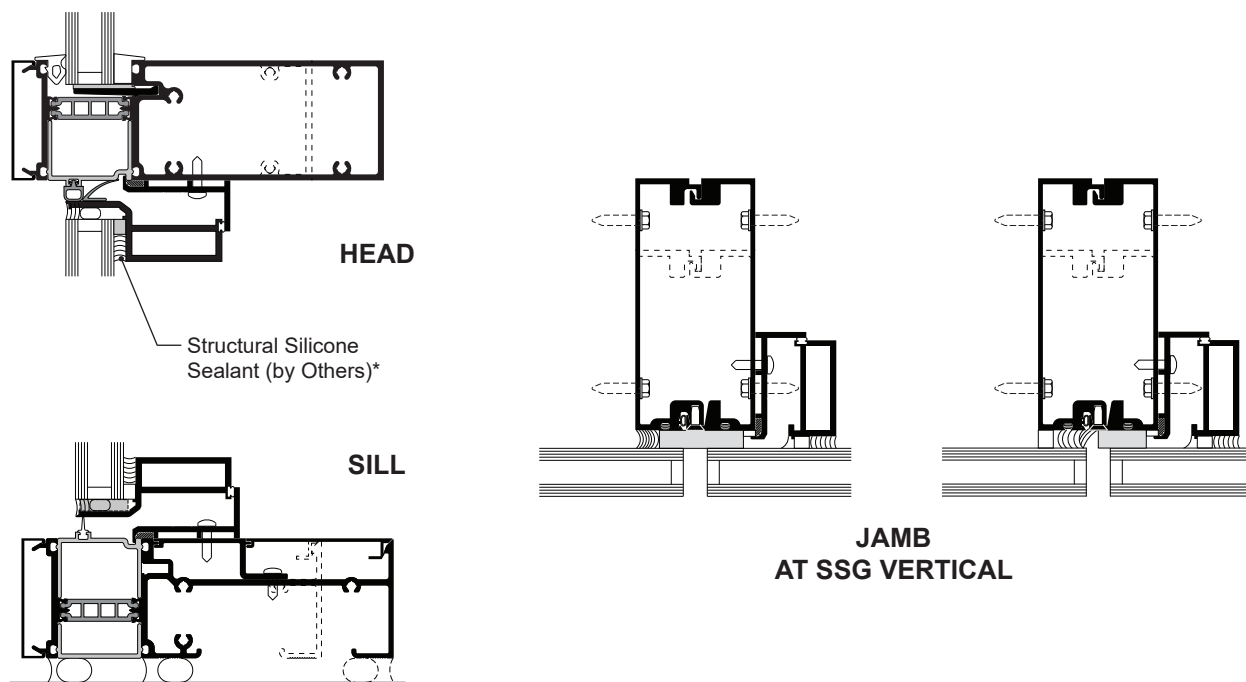

* INSTALLER NOTE: Installer is responsible for all required compatibility review and approvals with the Structural Silicone Manufacturer and the Insulating Glass Unit Manufacturer.

Additional information and CAD details are available at www.kawneer.com

Laws and building and safety codes governing the design and use of Kawneer products, such as glazed entrance, window, and curtain wall products, vary widely. Kawneer does not control the selection of product configurations, operating hardware, or glazing materials, and assumes no responsibility therefor.

Kawneer reserves the right to change configuration without prior notice when deemed necessary for product improvement.
© 2024, Kawneer Company, Inc.

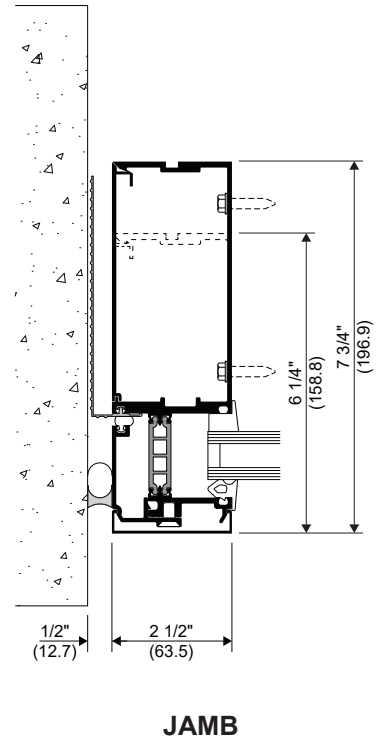
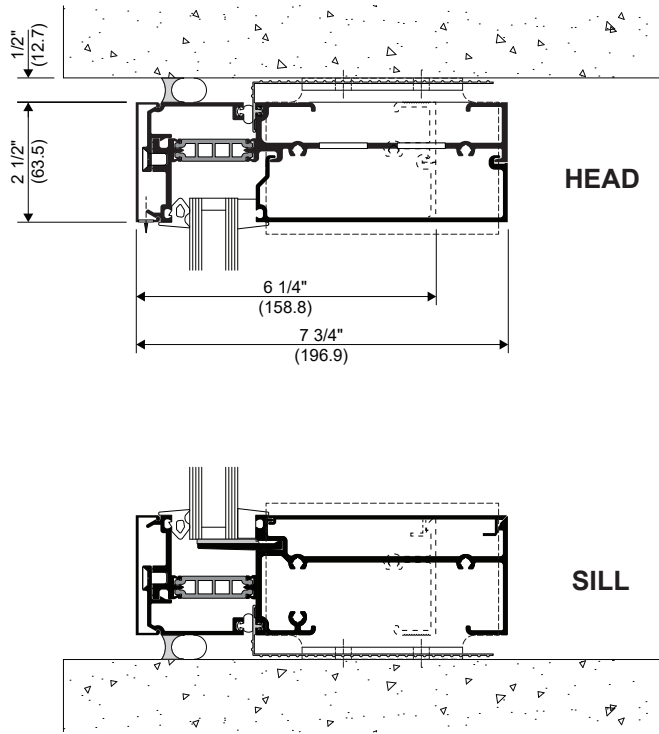

Actual project conditions will determine specific anchor design. Details on this page are for reference only.

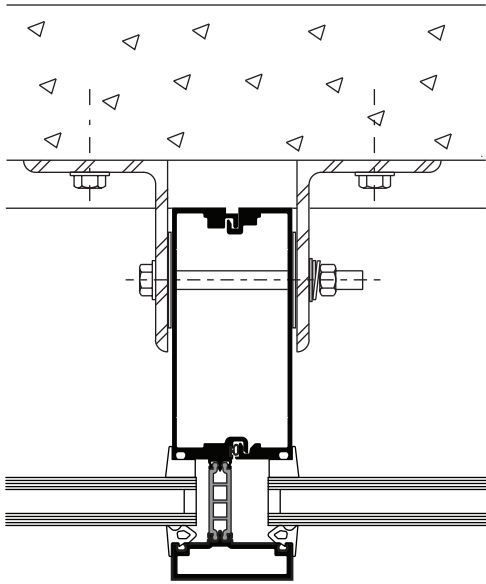

ANCHORING TO FLOOR SLAB

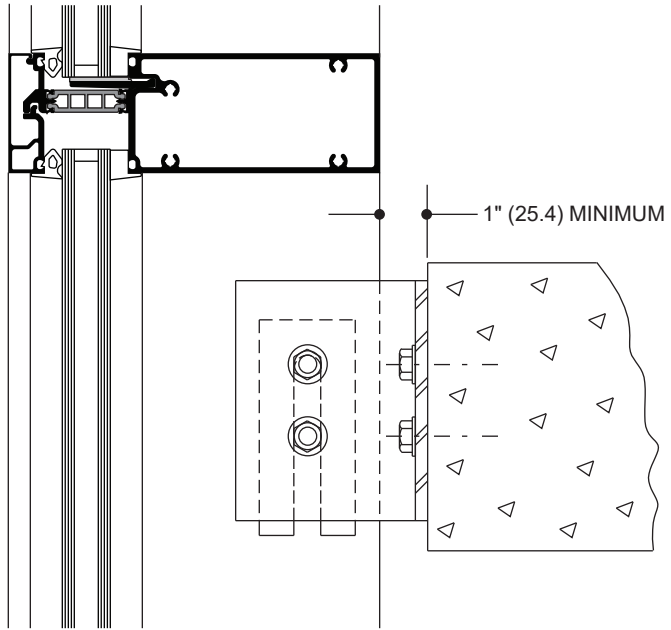

NOTE: 7-3/4" SYSTEM SHOWN, 6-1/4" SYSTEM SIMILAR

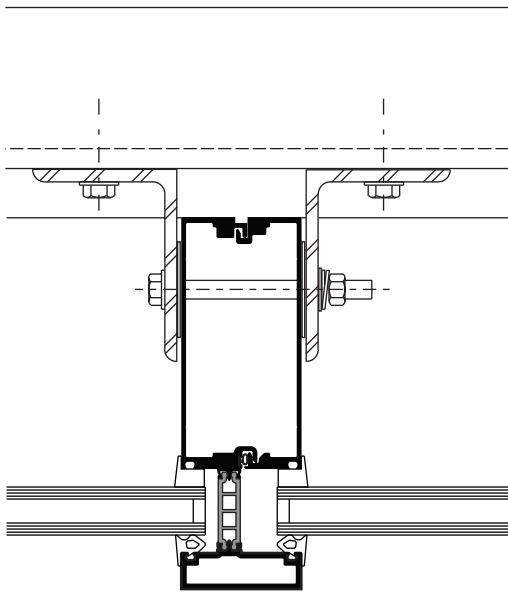

ANCHORING TO SUPPORT STEEL

NOTE: 7-3/4" SYSTEM SHOWN,
6-1/4" SYSTEM SIMILAR

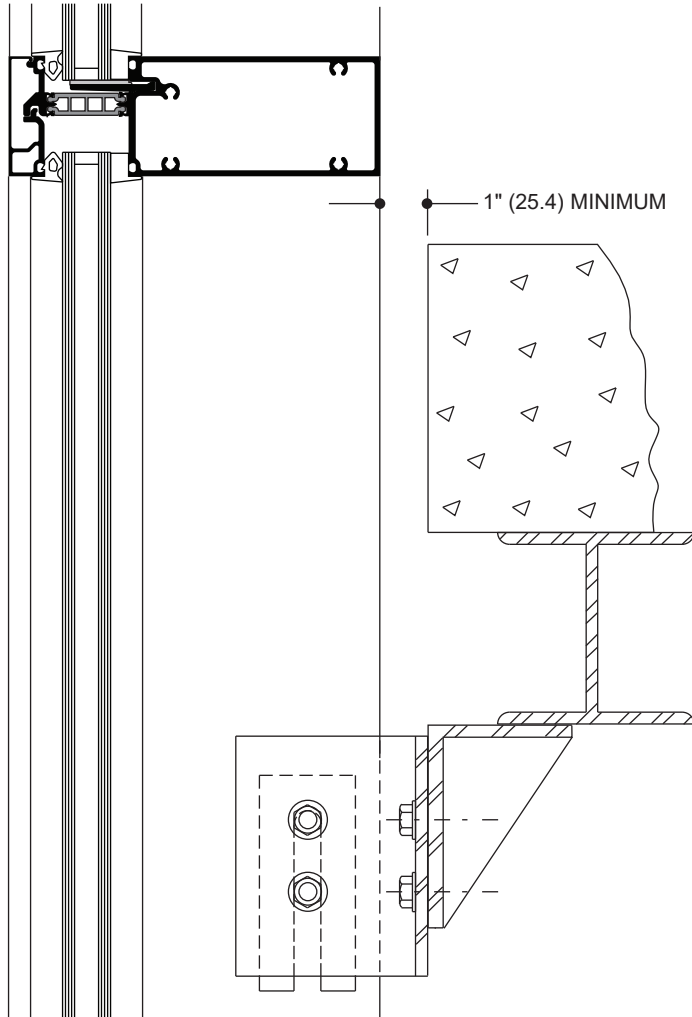

Laws and building and safety codes governing the design and use of Kawneer products, such as glazed entrance, window, and curtain wall products, vary widely. Kawneer does not control the selection of product configurations, operating hardware, or glazing materials, and assumes no responsibility therefor.

Kawneer reserves the right to change configuration without prior notice when deemed necessary for product improvement.
© 2024, Kawneer Company, Inc.

Actual project conditions will determine specific anchor design. Details on this page are for reference only.

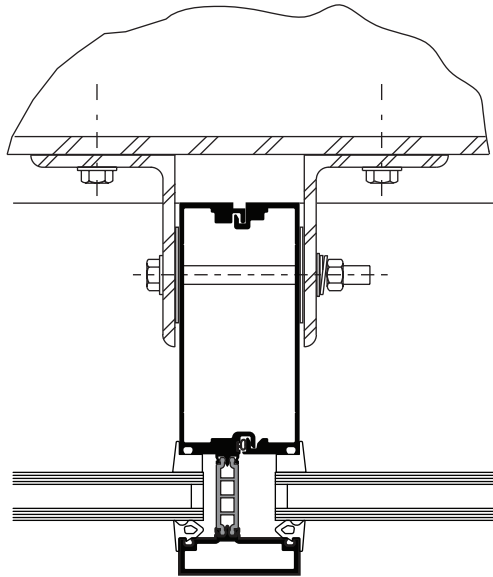

ANCHORING TO HORIZONTAL STRUCTURAL STEEL

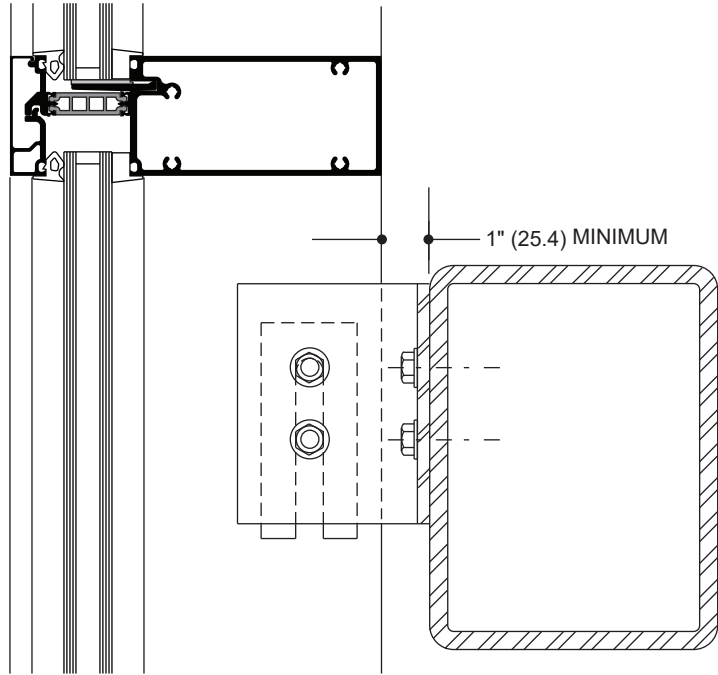

NOTE: 7-3/4" SYSTEM SHOWN, 6-1/4" SYSTEM SIMILAR

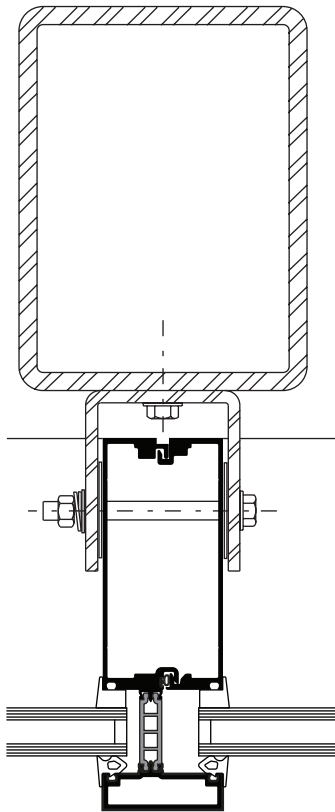

ANCHORING TO VERTICAL STRUCTURAL STEEL

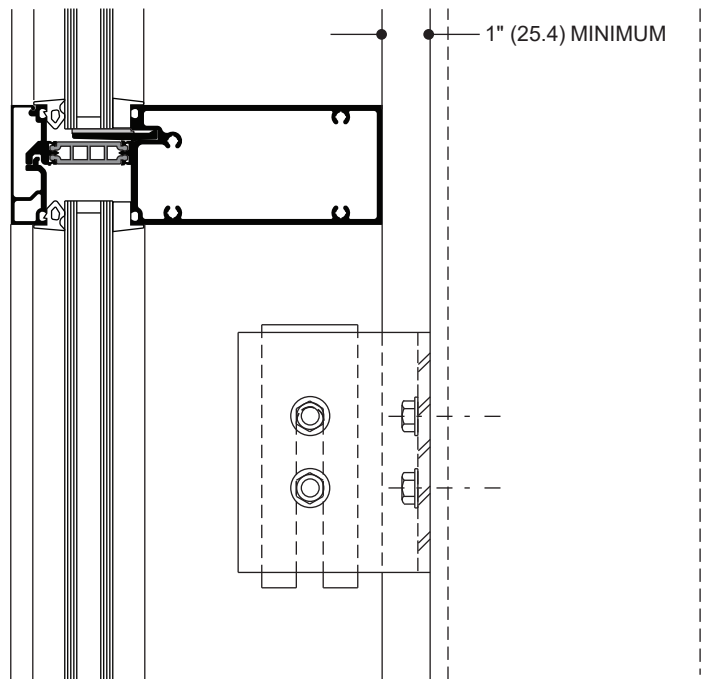

NOTE: 7-3/4" SYSTEM SHOWN, 6-1/4" SYSTEM SIMILAR

Laws and building and safety codes governing the design and use of Kawneer products, such as glazed entrance, window, and curtain wall products, vary widely. Kawneer does not control the selection of product configurations, operating hardware, or glazing materials, and assumes no responsibility therefor.

Kawneer reserves the right to change configuration without prior notice when deemed necessary for product improvement.
© 2024, Kawneer Company, Inc.

Actual project conditions will determine specific anchor design. Details on this page are for reference only.

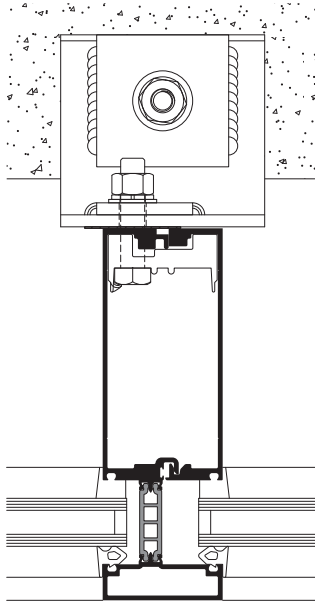

**SINGLE DEADLOAD
BACK ANCHOR**

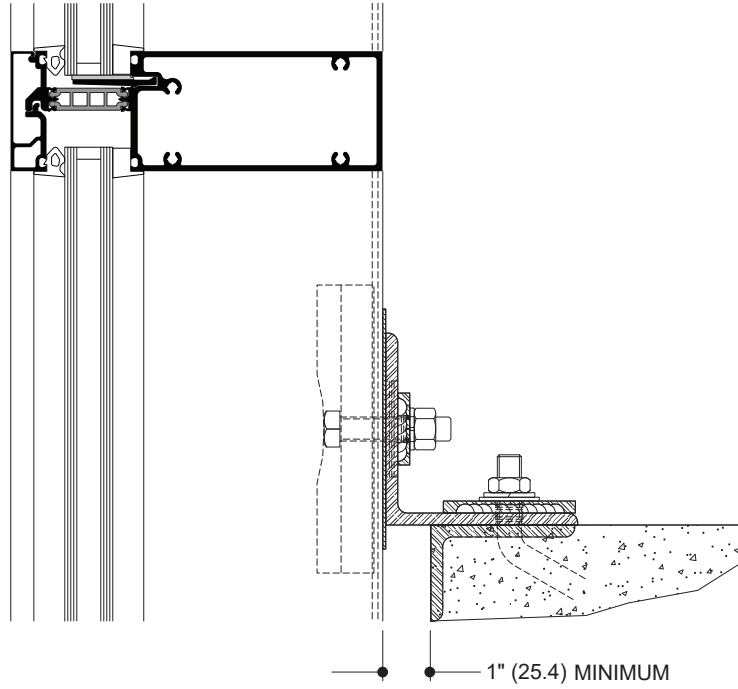

NOTE: 7-3/4" SYSTEM SHOWN, 6-1/4" SYSTEM SIMILAR

Laws and building and safety codes governing the design and use of Kawneer products, such as glazed entrance, window, and curtain wall products, vary widely. Kawneer does not control the selection of product configurations, operating hardware, or glazing materials, and assumes no responsibility therefor.

Kawneer reserves the right to change configuration without prior notice when deemed necessary for product improvement.
© 2024, Kawneer Company, Inc.

WIND LOAD CHARTS

Mullions are designed for deflection limitations in accordance with AAMA TIR-A11 of L/175 up to 13' 6" and L/240 +1/4" above 13' 6". These curves are for mullions WITH HORIZONTALS and are based on engineering calculations for stress and deflection. Allowable wind load stress for ALUMINUM 15,152 psi (104 MPa), STEEL 30,000 psi (207 MPa). Charted curves, in all cases are for the limiting value. Wind load charts contained herein are based upon nominal wind load utilized in allowable stress design. A conversion from Load Resistance Factor Design (LRFD) is provided. To convert ultimate wind loads to nominal loads, multiply ultimate wind loads by a factor of 0.6 per ASCE/SEI 7. A 4/3 increase in allowable stress has not been used to develop these curves. For special situations not covered by these curves, contact your Kawneer representative for additional information.

DEADLOAD CHARTS

Horizontal or deadload limitations are based upon 1/8" (3.2), maximum allowable deflection at the center of an intermediate horizontal member. The accompanying charts are calculated for 1" (25.4) thick insulating glass or 1-5/16" (33.34) thick insulating glass supported on two setting blocks placed at the loading points shown.

SINGLE SPAN

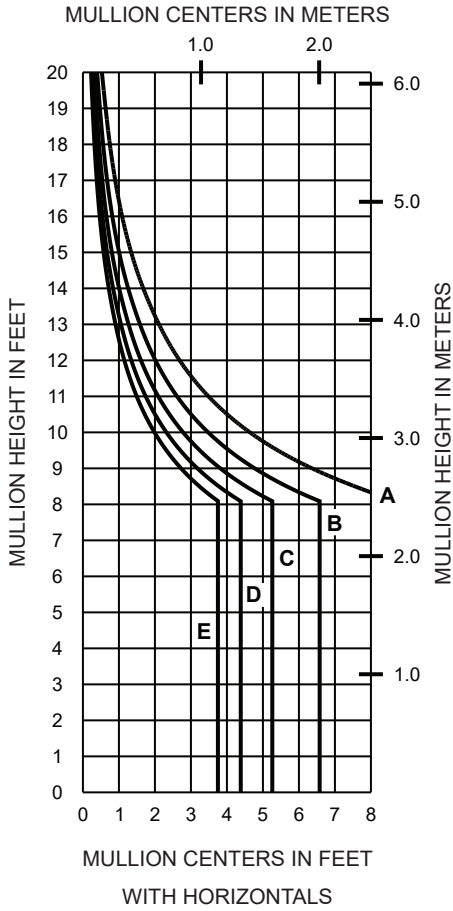

	Allowable Stress Design Load	LRFD Ultimate Design Load
A =	30 PSF (1440)	50 PSF (2400)
B =	40 PSF (1920)	67 PSF (3200)
C =	50 PSF (2400)	83 PSF (4000)
D =	60 PSF (2880)	100 PSF (4790)
E =	70 PSF (3360)	117 PSF (5600)



SINGLE SPAN

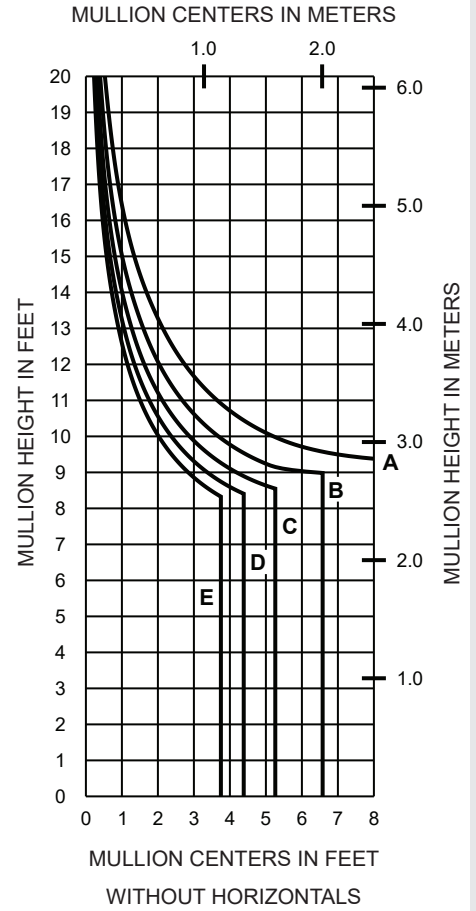

TWIN SPAN

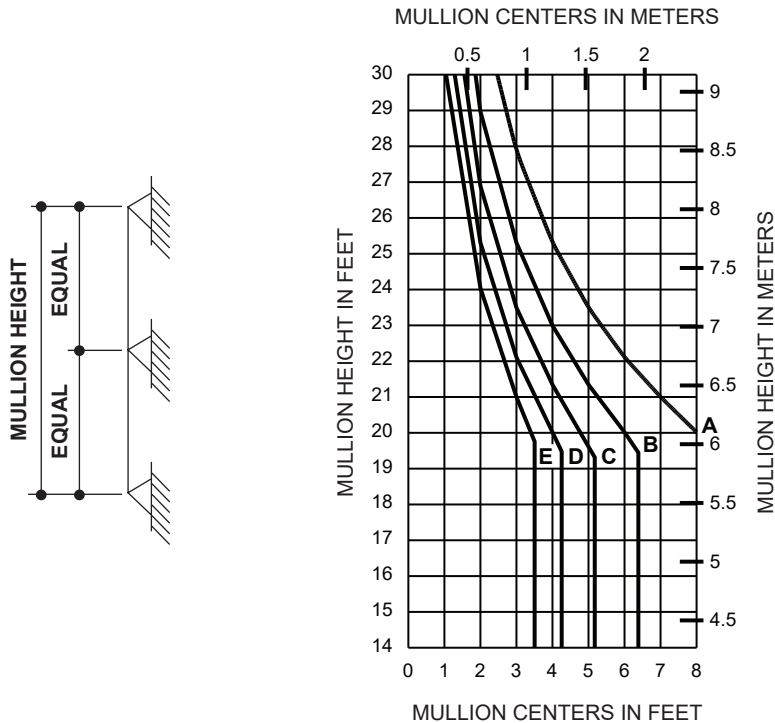

185006 185005
 $I = 4.553 (424.47 \times 10^4)$
 $S = 2.400 (62.78 \times 10^3)$

Laws and building and safety codes governing the design and use of Kawneer products, such as glazed entrance, window, and curtain wall products, vary widely. Kawneer does not control the selection of product configurations, operating hardware, or glazing materials, and assumes no responsibility therefor.

Kawneer reserves the right to change configuration without prior notice when deemed necessary for product improvement.
 © 2024, Kawneer Company, Inc.

SINGLE SPAN

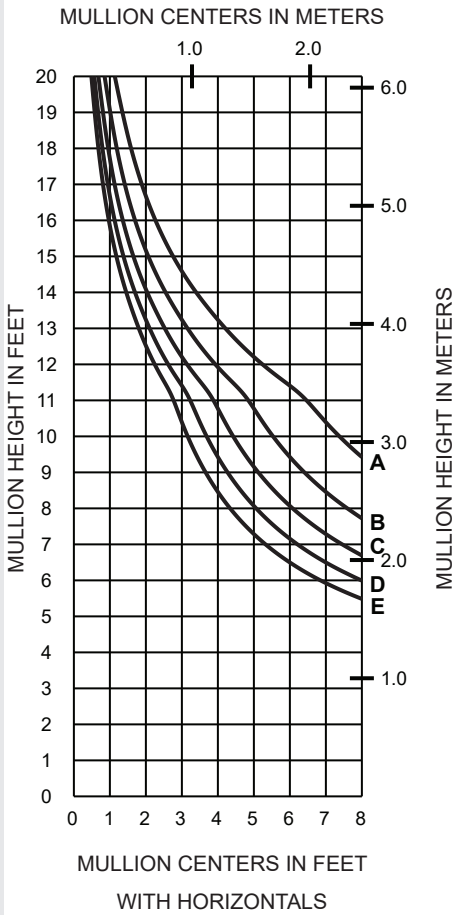

	Allowable Stress Design Load	LRFD Ultimate Design Load
A =	30 PSF (1440)	50 PSF (2400)
B =	40 PSF (1920)	67 PSF (3200)
C =	50 PSF (2400)	83 PSF (4000)
D =	60 PSF (2880)	100 PSF (4790)
E =	70 PSF (3360)	117 PSF (5600)

SINGLE SPAN

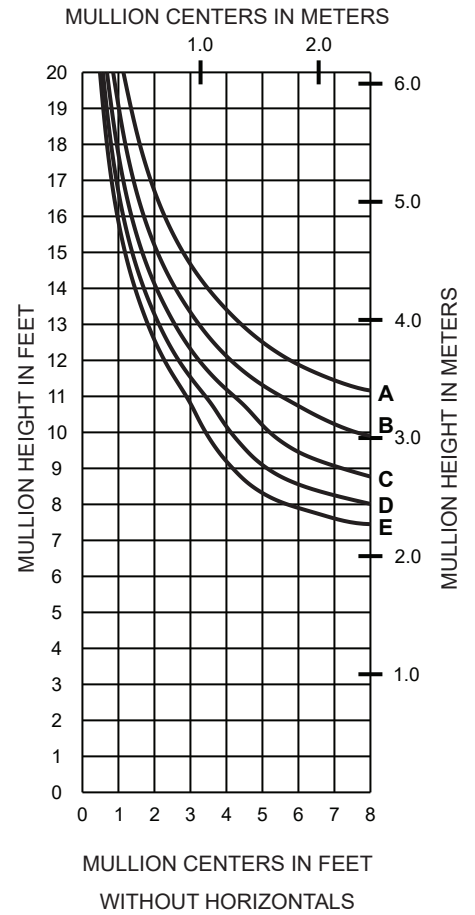

TWIN SPAN

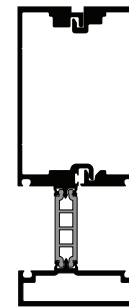
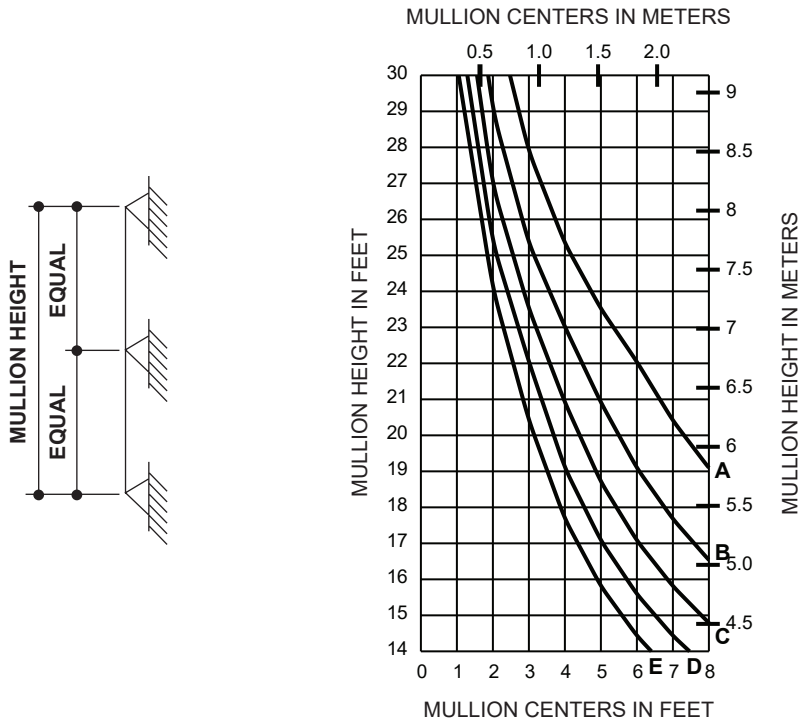

185223 185004

WINDLOAD CHARTS ARE BASED ON COMPOSITE PROPERTIES WHICH ARE CALCULATED IN ACCORDANCE WITH AAMA TIR-8 AND AAMA 505

Laws and building and safety codes governing the design and use of Kawneer products, such as glazed entrance, window, and curtain wall products, vary widely. Kawneer does not control the selection of product configurations, operating hardware, or glazing materials, and assumes no responsibility therefor.

Kawneer reserves the right to change configuration without prior notice when deemed necessary for product improvement.
© 2024, Kawneer Company, Inc.

SINGLE SPAN

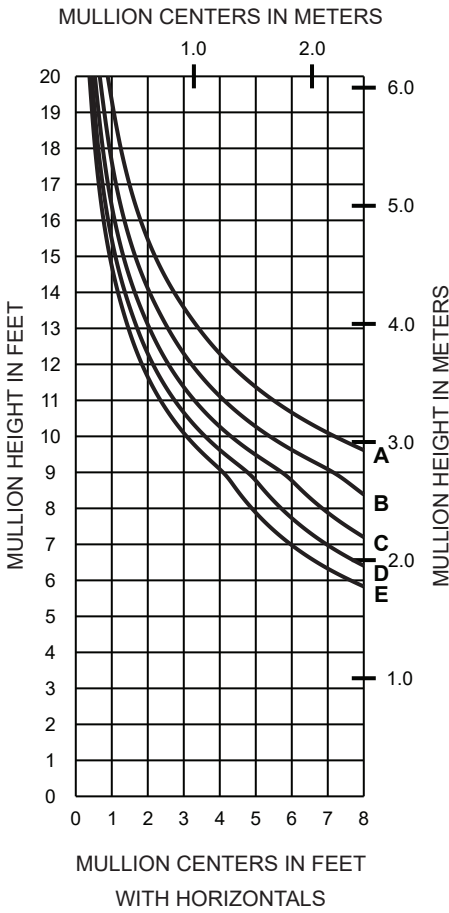

	Allowable Stress Design Load	LRFD Ultimate Design Load
A =	30 PSF (1440)	50 PSF (2400)
B =	40 PSF (1920)	67 PSF (3200)
C =	50 PSF (2400)	83 PSF (4000)
D =	60 PSF (2880)	100 PSF (4790)
E =	70 PSF (3360)	117 PSF (5600)



SINGLE SPAN

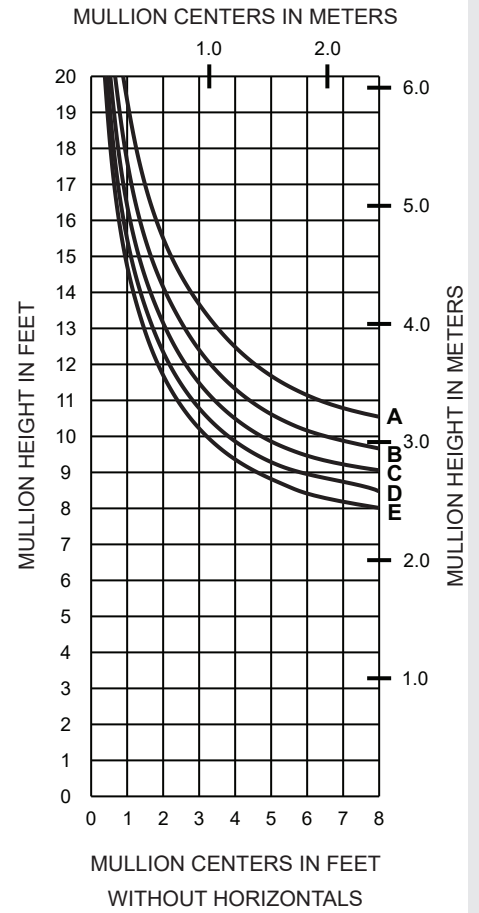

TWIN SPAN

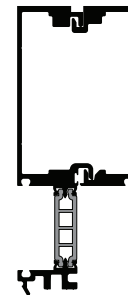
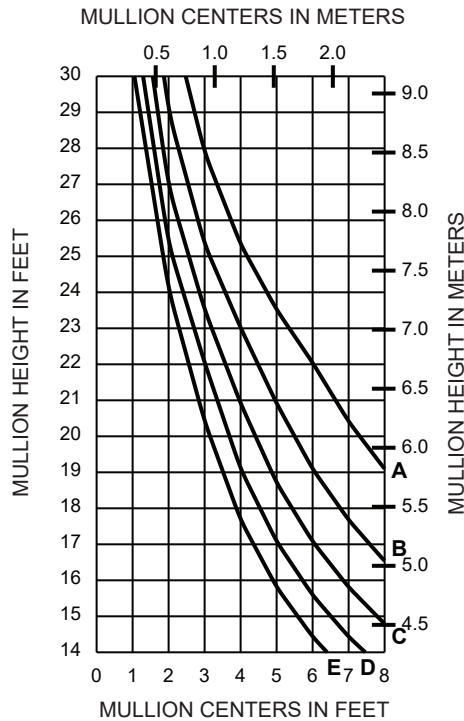
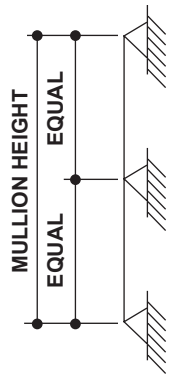

184225 185004

WINDLOAD CHARTS ARE BASED ON COMPOSITE PROPERTIES WHICH ARE CALCULATED IN ACCORDANCE WITH AAMA TIR-8 AND AAMA 505

Laws and building and safety codes governing the design and use of Kawneer products, such as glazed entrance, window, and curtain wall products, vary widely. Kawneer does not control the selection of product configurations, operating hardware, or glazing materials, and assumes no responsibility therefor.

Kawneer reserves the right to change configuration without prior notice when deemed necessary for product improvement.
© 2024, Kawneer Company, Inc.

SINGLE SPAN

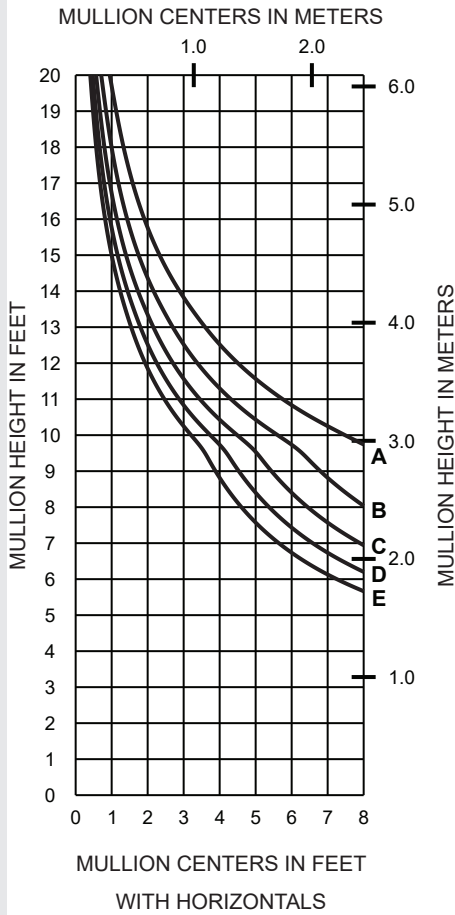

	Allowable Stress Design Load	LRFD Ultimate Design Load
A =	30 PSF (1440)	50 PSF (2400)
B =	40 PSF (1920)	67 PSF (3200)
C =	50 PSF (2400)	83 PSF (4000)
D =	60 PSF (2880)	100 PSF (4790)
E =	70 PSF (3360)	117 PSF (5600)

SINGLE SPAN

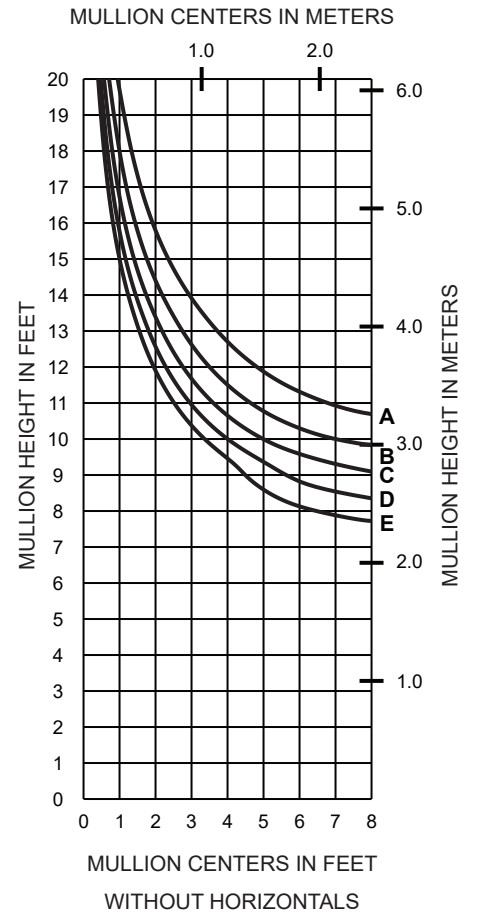

TWIN SPAN

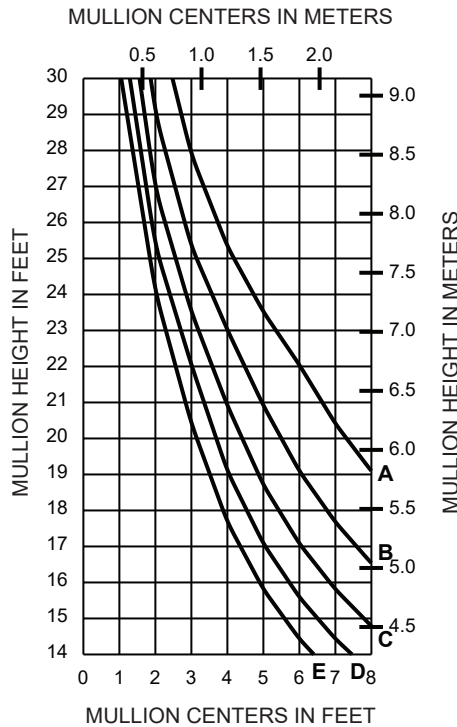
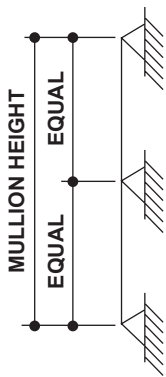

185233 185004

WINDLOAD CHARTS ARE BASED ON COMPOSITE PROPERTIES WHICH ARE CALCULATED IN ACCORDANCE WITH AAMA TIR-8 AND AAMA 505

Laws and building and safety codes governing the design and use of Kawneer products, such as glazed entrance, window, and curtain wall products, vary widely. Kawneer does not control the selection of product configurations, operating hardware, or glazing materials, and assumes no responsibility therefor.

Kawneer reserves the right to change configuration without prior notice when deemed necessary for product improvement.
© 2024, Kawneer Company, Inc.

SINGLE SPAN

	Allowable Stress Design Load	LRFD Ultimate Design Load
A =	30 PSF (1440)	50 PSF (2400)
B =	40 PSF (1920)	67 PSF (3200)
C =	50 PSF (2400)	83 PSF (4000)
D =	60 PSF (2880)	100 PSF (4790)
E =	70 PSF (3360)	117 PSF (5600)

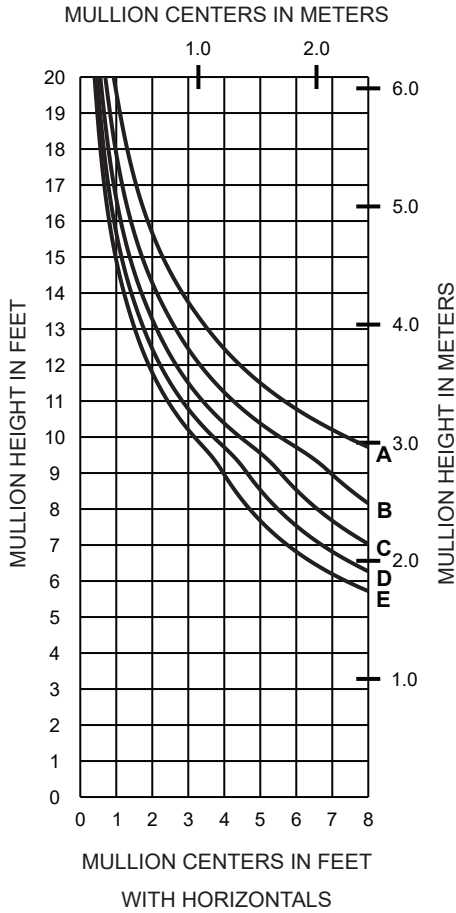

SINGLE SPAN

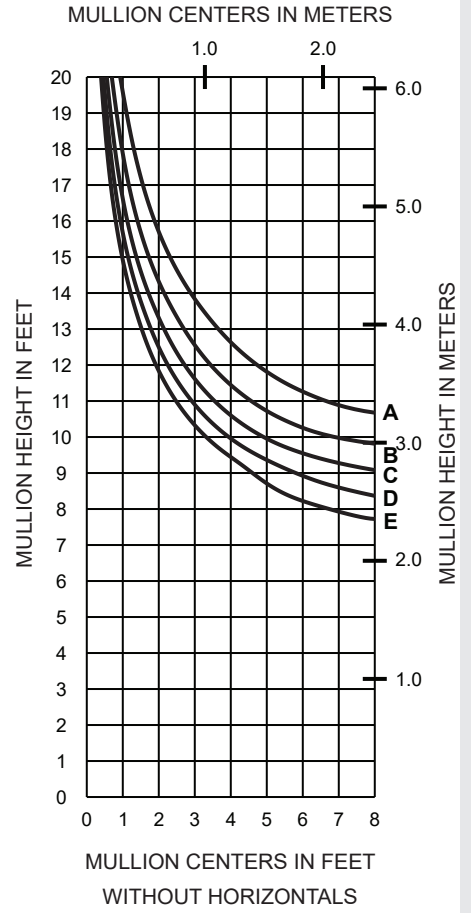

TWIN SPAN

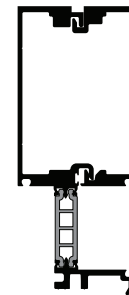
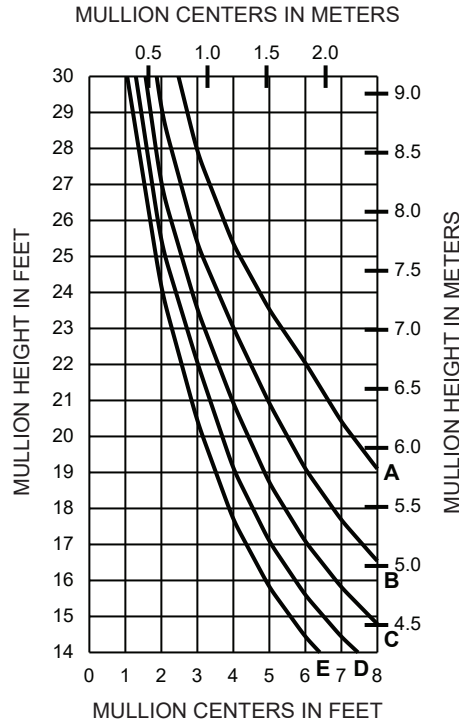
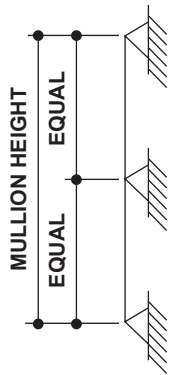

185235 185004

WINDLOAD CHARTS ARE BASED ON COMPOSITE PROPERTIES WHICH ARE CALCULATED IN ACCORDANCE WITH AAMA TIR-8 AND AAMA 505

Laws and building and safety codes governing the design and use of Kawneer products, such as glazed entrance, window, and curtain wall products, vary widely. Kawneer does not control the selection of product configurations, operating hardware, or glazing materials, and assumes no responsibility therefor.

Kawneer reserves the right to change configuration without prior notice when deemed necessary for product improvement.
© 2024, Kawneer Company, Inc.

SINGLE SPAN

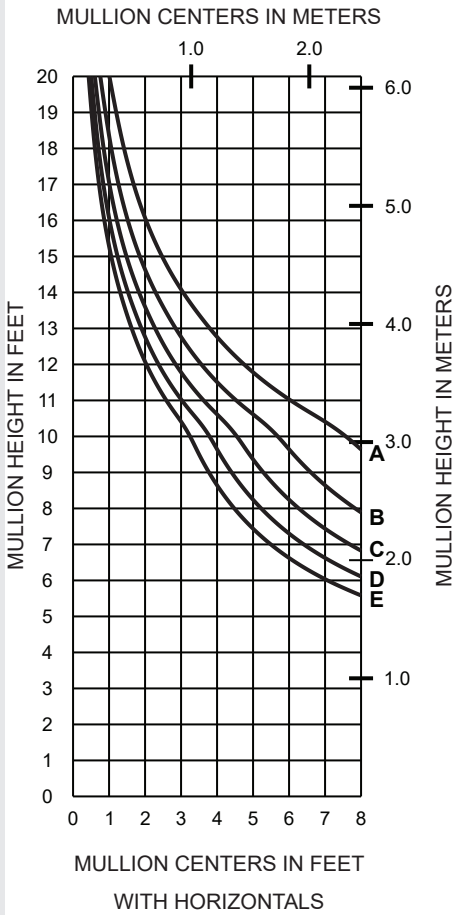

	Allowable Stress Design Load	LRFD Ultimate Design Load
A =	30 PSF (1440)	50 PSF (2400)
B =	40 PSF (1920)	67 PSF (3200)
C =	50 PSF (2400)	83 PSF (4000)
D =	60 PSF (2880)	100 PSF (4790)
E =	70 PSF (3360)	117 PSF (5600)



SINGLE SPAN

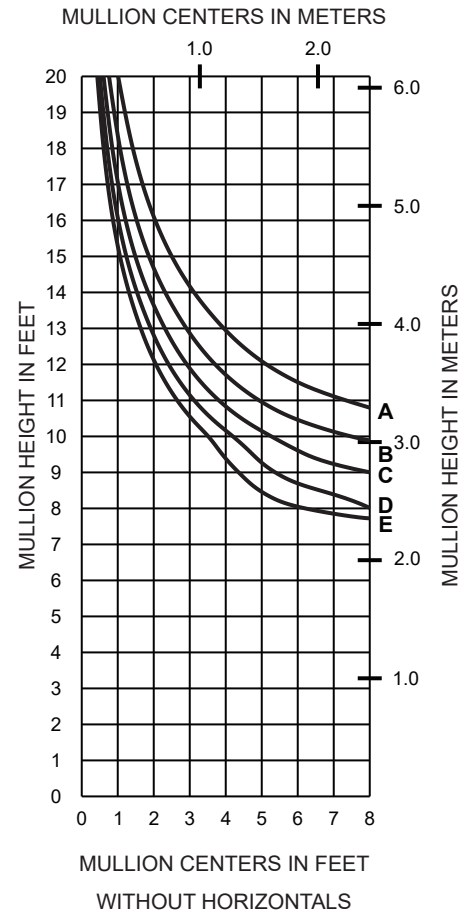

TWIN SPAN

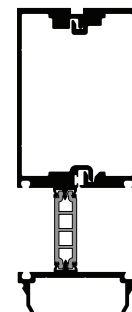
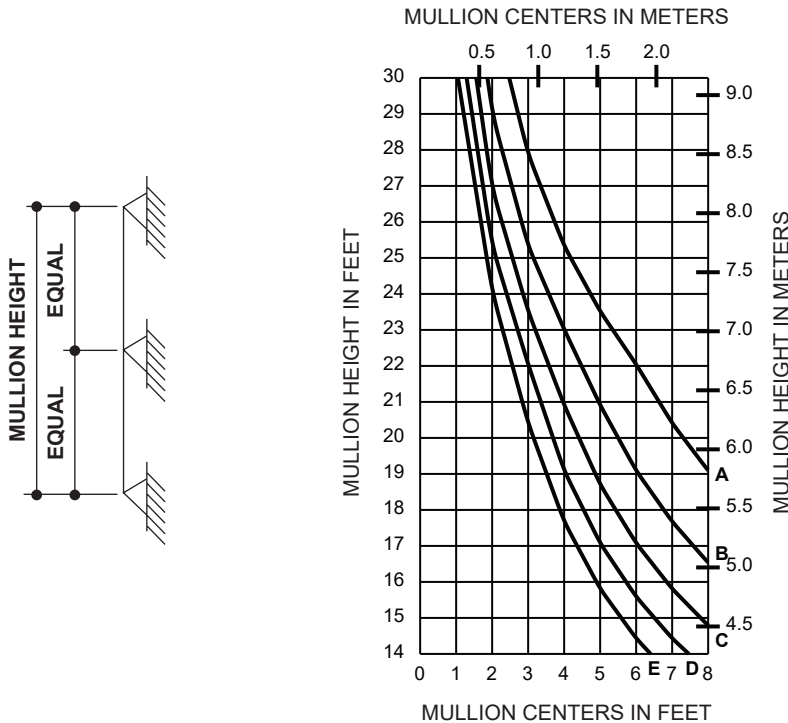

185263 185004

WINDLOAD CHARTS ARE BASED ON COMPOSITE PROPERTIES WHICH ARE CALCULATED IN ACCORDANCE WITH AAMA TIR-8 AND AAMA 505

Laws and building and safety codes governing the design and use of Kawneer products, such as glazed entrance, window, and curtain wall products, vary widely. Kawneer does not control the selection of product configurations, operating hardware, or glazing materials, and assumes no responsibility therefor.

Kawneer reserves the right to change configuration without prior notice when deemed necessary for product improvement.
© 2024, Kawneer Company, Inc.

SINGLE SPAN

	Allowable Stress Design Load	LRFD Ultimate Design Load
A =	30 PSF (1440)	50 PSF (2400)
B =	40 PSF (1920)	67 PSF (3200)
C =	50 PSF (2400)	83 PSF (4000)
D =	60 PSF (2880)	100 PSF (4790)
E =	70 PSF (3360)	117 PSF (5600)

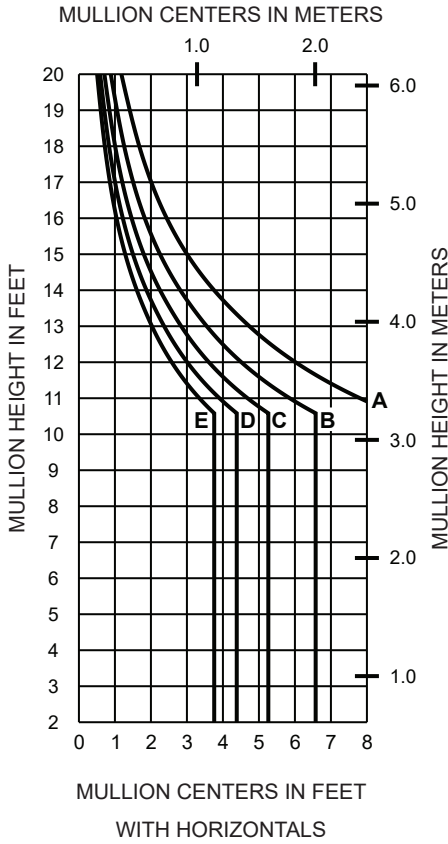

SINGLE SPAN

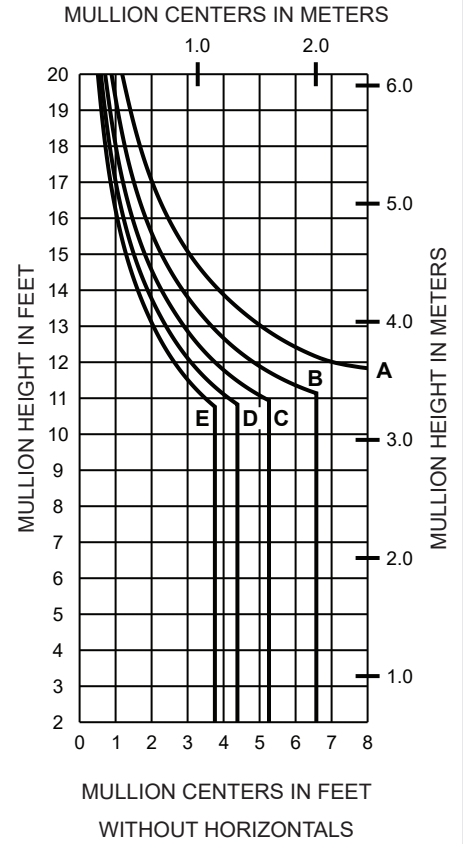

TWIN SPAN

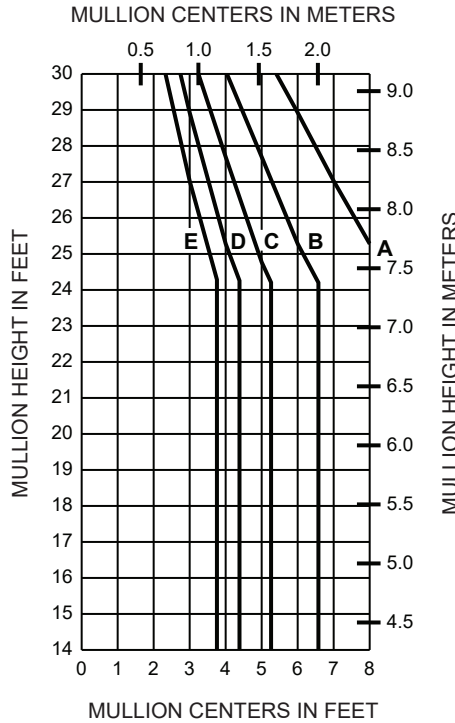
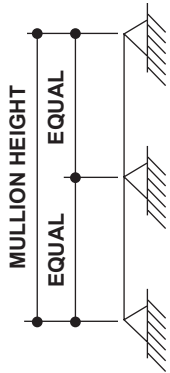

184005 184006
 $I = 10.198 (424.47 \times 10^4)$
 $S = 3.831 (62.78 \times 10^3)$

Laws and building and safety codes governing the design and use of Kawneer products, such as glazed entrance, window, and curtain wall products, vary widely. Kawneer does not control the selection of product configurations, operating hardware, or glazing materials, and assumes no responsibility therefor.

Kawneer reserves the right to change configuration without prior notice when deemed necessary for product improvement.
 © 2024, Kawneer Company, Inc.

SINGLE SPAN

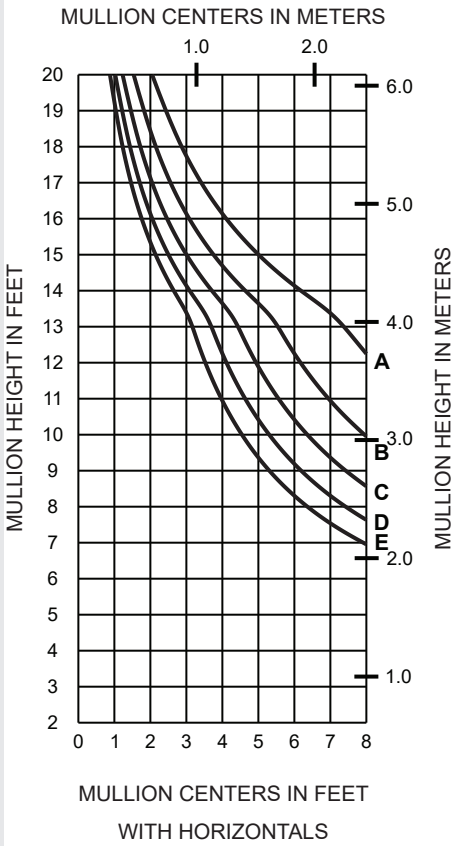

	Allowable Stress Design Load	LRFD Ultimate Design Load
A =	30 PSF (1440)	50 PSF (2400)
B =	40 PSF (1920)	67 PSF (3200)
C =	50 PSF (2400)	83 PSF (4000)
D =	60 PSF (2880)	100 PSF (4790)
E =	70 PSF (3360)	117 PSF (5600)



SINGLE SPAN

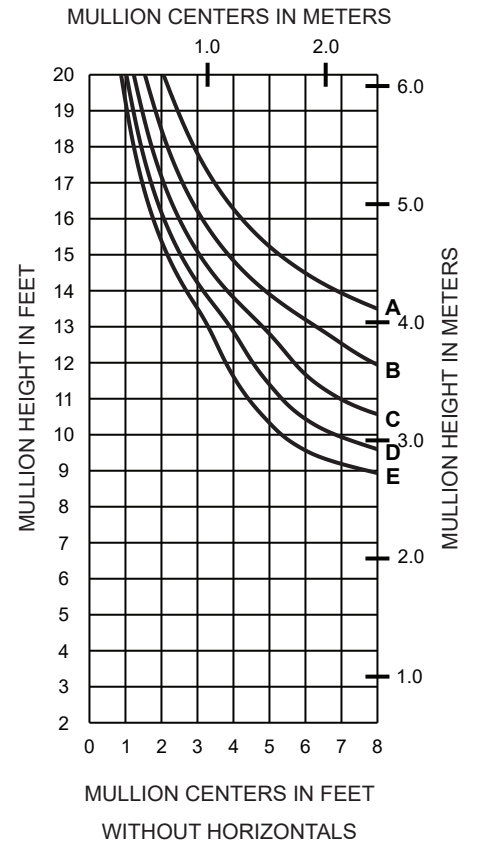

TWIN SPAN

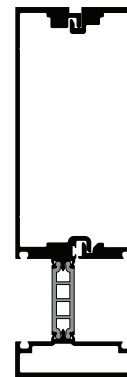
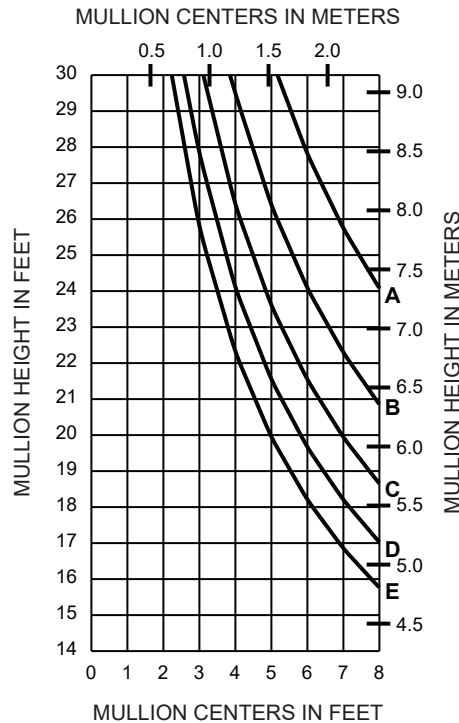
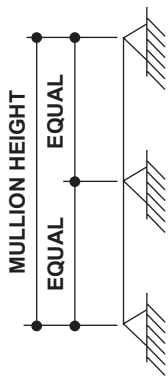

184223 184004

WINDLOAD CHARTS ARE BASED ON COMPOSITE PROPERTIES WHICH ARE CALCULATED IN ACCORDANCE WITH AAMA TIR-8 AND AAMA 505

Laws and building and safety codes governing the design and use of Kawneer products, such as glazed entrance, window, and curtain wall products, vary widely. Kawneer does not control the selection of product configurations, operating hardware, or glazing materials, and assumes no responsibility therefor.

Kawneer reserves the right to change configuration without prior notice when deemed necessary for product improvement.
© 2024, Kawneer Company, Inc.

SINGLE SPAN

	Allowable Stress Design Load	LRFD Ultimate Design Load
A =	30 PSF (1440)	50 PSF (2400)
B =	40 PSF (1920)	67 PSF (3200)
C =	50 PSF (2400)	83 PSF (4000)
D =	60 PSF (2880)	100 PSF (4790)
E =	70 PSF (3360)	117 PSF (5600)

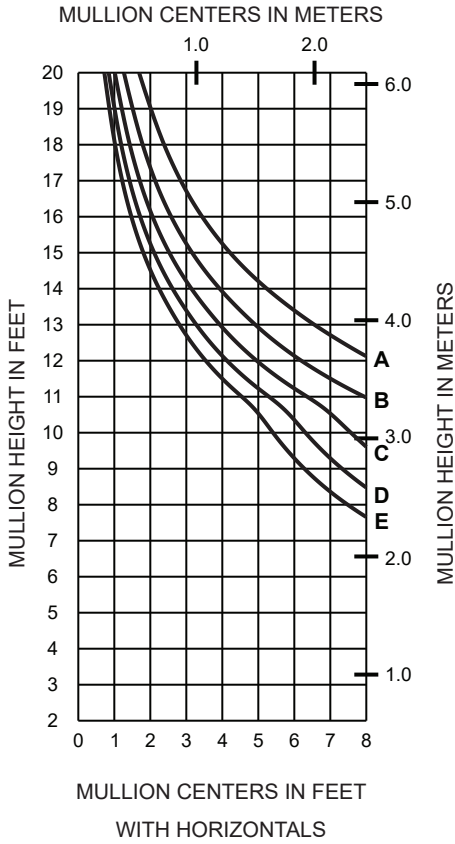

SINGLE SPAN

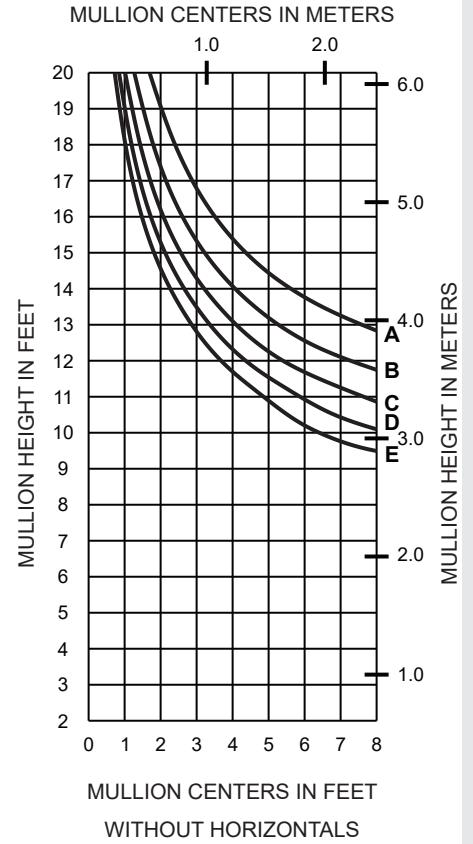

TWIN SPAN

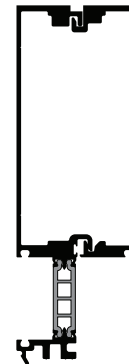
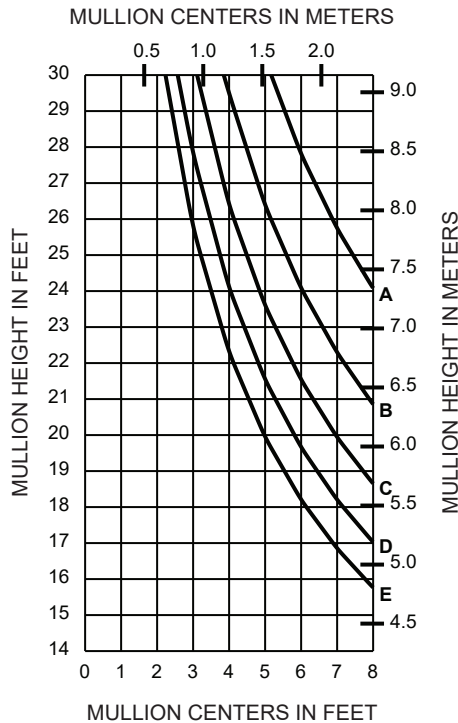
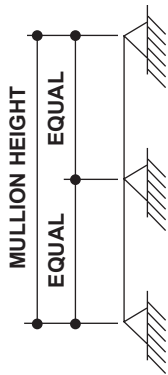

184225 184004

WINDLOAD CHARTS ARE BASED ON COMPOSITE PROPERTIES WHICH ARE CALCULATED IN ACCORDANCE WITH AAMA TIR-8 AND AAMA 505

Laws and building and safety codes governing the design and use of Kawneer products, such as glazed entrance, window, and curtain wall products, vary widely. Kawneer does not control the selection of product configurations, operating hardware, or glazing materials, and assumes no responsibility therefor.

Kawneer reserves the right to change configuration without prior notice when deemed necessary for product improvement.
© 2024, Kawneer Company, Inc.

SINGLE SPAN

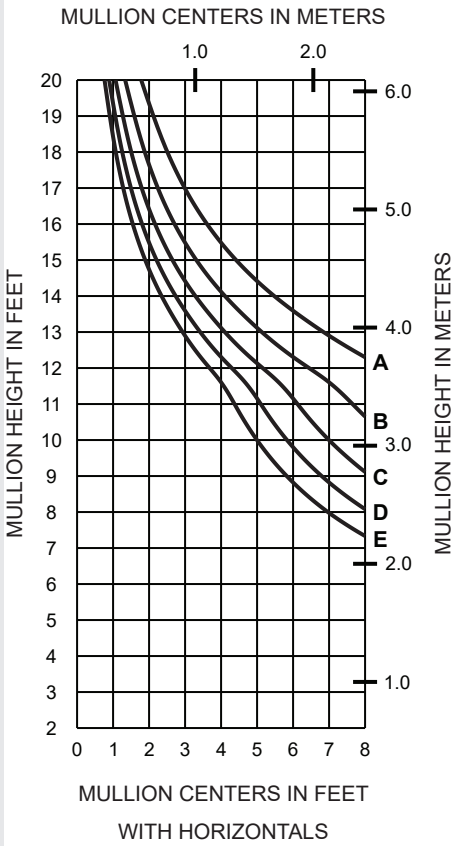

	Allowable Stress Design Load	LRFD Ultimate Design Load
A =	30 PSF (1440)	50 PSF (2400)
B =	40 PSF (1920)	67 PSF (3200)
C =	50 PSF (2400)	83 PSF (4000)
D =	60 PSF (2880)	100 PSF (4790)
E =	70 PSF (3360)	117 PSF (5600)



SINGLE SPAN

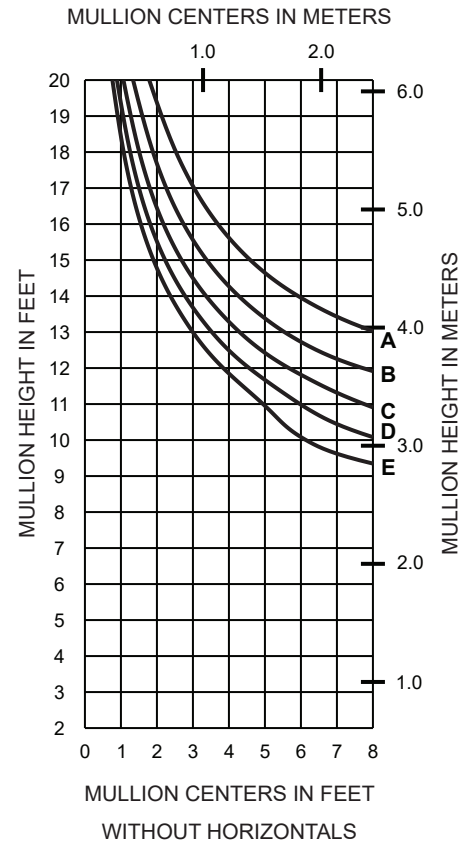

TWIN SPAN

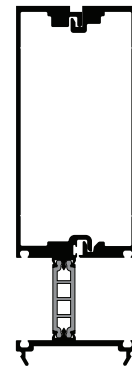
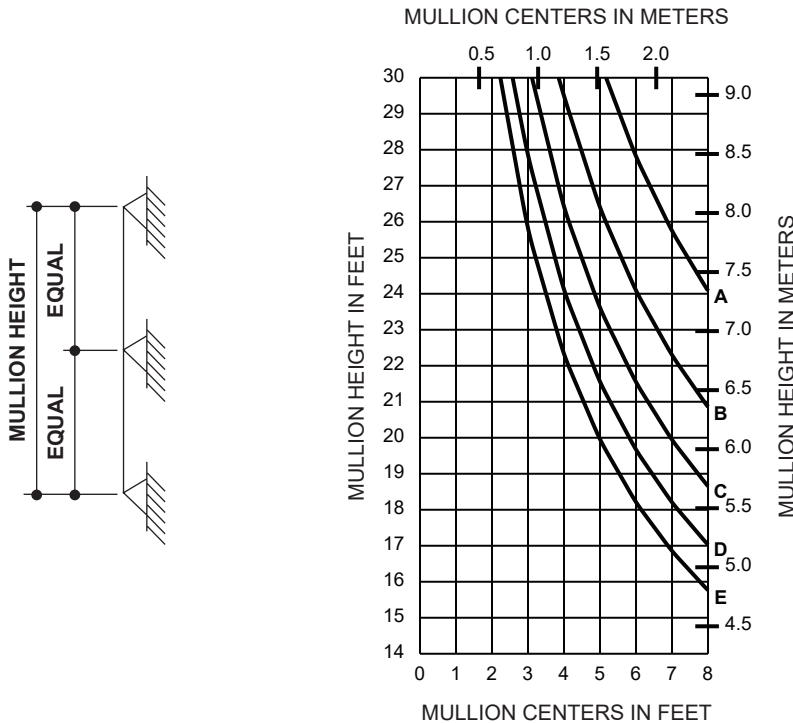

184233 184004

WINDLOAD CHARTS ARE BASED ON COMPOSITE PROPERTIES WHICH ARE CALCULATED IN ACCORDANCE WITH AAMA TIR-8 AND AAMA 505

Laws and building and safety codes governing the design and use of Kawneer products, such as glazed entrance, window, and curtain wall products, vary widely. Kawneer does not control the selection of product configurations, operating hardware, or glazing materials, and assumes no responsibility therefor.

Kawneer reserves the right to change configuration without prior notice when deemed necessary for product improvement.
© 2024, Kawneer Company, Inc.

SINGLE SPAN

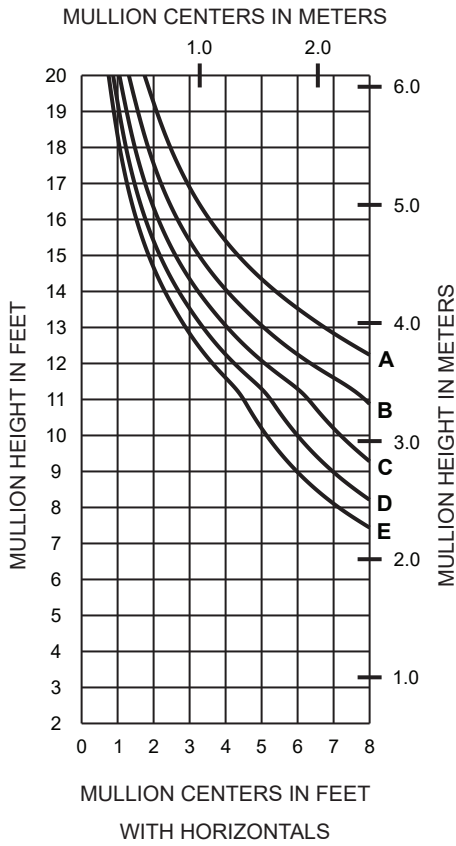

	Allowable Stress Design Load	LRFD Ultimate Design Load
A =	30 PSF (1440)	50 PSF (2400)
B =	40 PSF (1920)	67 PSF (3200)
C =	50 PSF (2400)	83 PSF (4000)
D =	60 PSF (2880)	100 PSF (4790)
E =	70 PSF (3360)	117 PSF (5600)



SINGLE SPAN

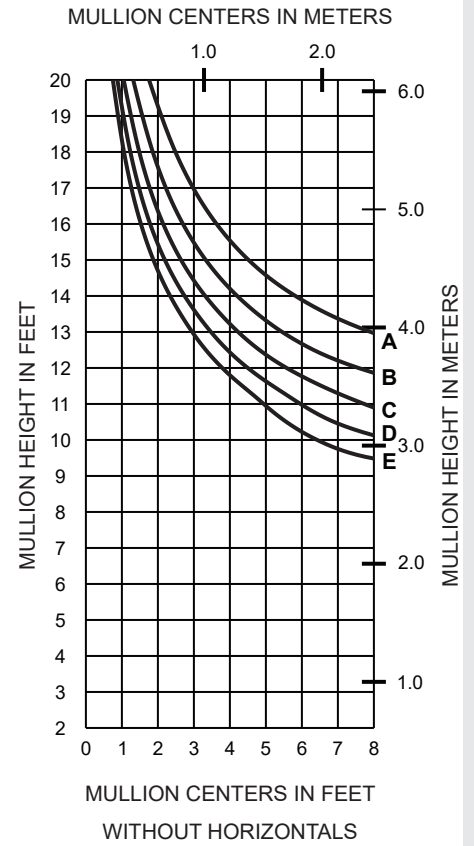

TWIN SPAN

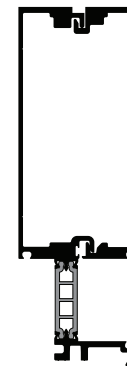
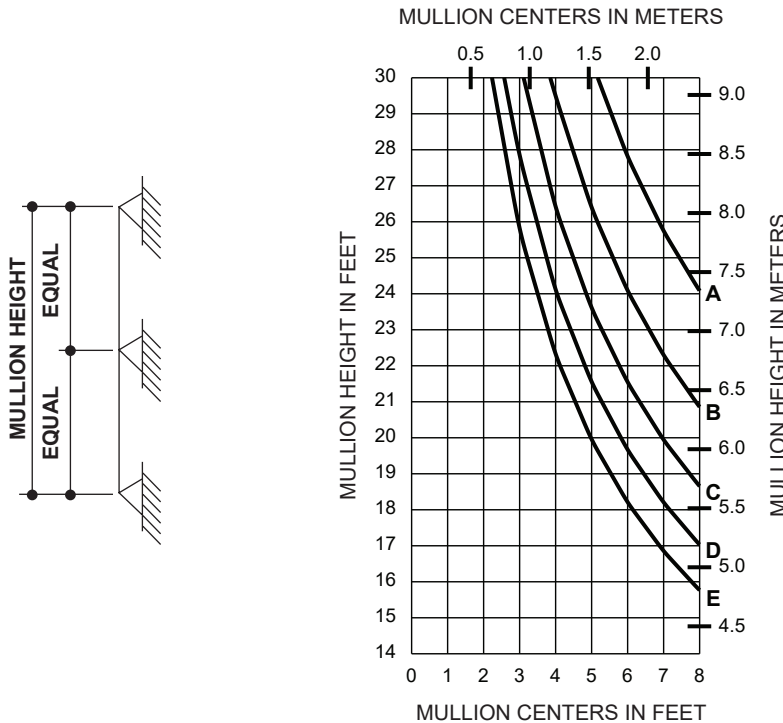

184235 184004

WINDLOAD CHARTS ARE BASED ON COMPOSITE PROPERTIES WHICH ARE CALCULATED IN ACCORDANCE WITH AAMA TIR-8 AND AAMA 505

Laws and building and safety codes governing the design and use of Kawneer products, such as glazed entrance, window, and curtain wall products, vary widely. Kawneer does not control the selection of product configurations, operating hardware, or glazing materials, and assumes no responsibility therefor.

Kawneer reserves the right to change configuration without prior notice when deemed necessary for product improvement.
© 2024, Kawneer Company, Inc.

SINGLE SPAN

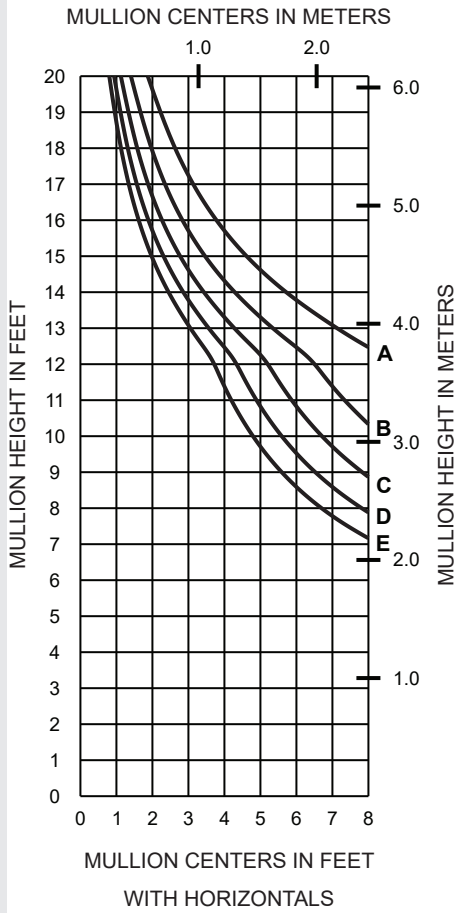

	Allowable Stress Design Load	LRFD Ultimate Design Load
A =	30 PSF (1440)	50 PSF (2400)
B =	40 PSF (1920)	67 PSF (3200)
C =	50 PSF (2400)	83 PSF (4000)
D =	60 PSF (2880)	100 PSF (4790)
E =	70 PSF (3360)	117 PSF (5600)



SINGLE SPAN

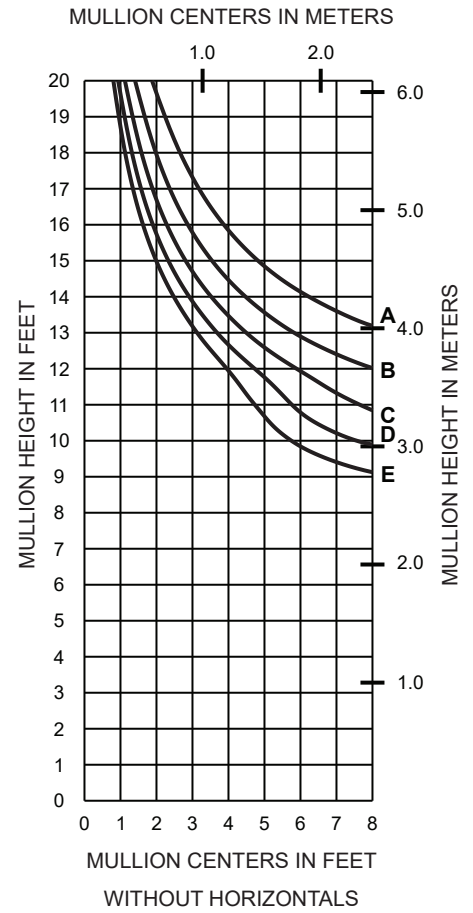

TWIN SPAN

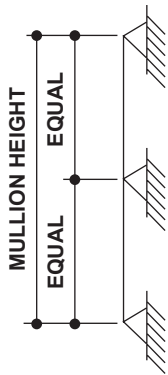
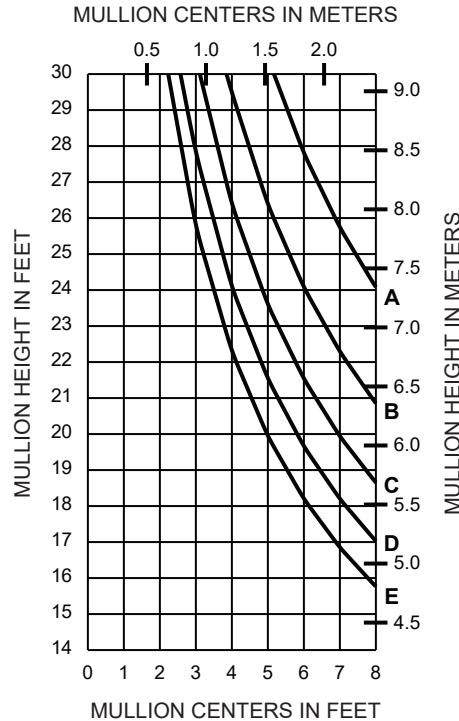

184263 184004

WINDLOAD CHARTS ARE BASED ON COMPOSITE PROPERTIES WHICH ARE CALCULATED IN ACCORDANCE WITH AAMA TIR-8 AND AAMA 505

Laws and building and safety codes governing the design and use of Kawneer products, such as glazed entrance, window, and curtain wall products, vary widely. Kawneer does not control the selection of product configurations, operating hardware, or glazing materials, and assumes no responsibility therefor.

Kawneer reserves the right to change configuration without prior notice when deemed necessary for product improvement.
© 2024, Kawneer Company, Inc.

(1" OR 1-1/4" INFILL)

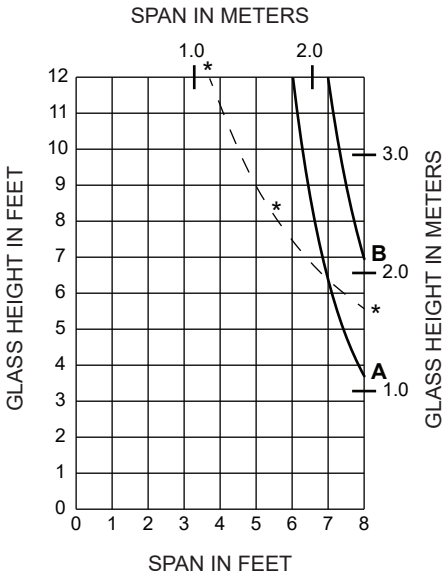

A = 1/4 POINT LOADING
B = 1/8 POINT LOADING
C = 1/10 POINT LOADING

NOTE: GLASS CHAIR CENTERLINE SHOULD NOT BE LESS THAN 6-1/2" (165.1) FROM EDGE OF GLASS.

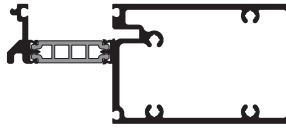

185224

I = 1.841 (76.63 x 10⁴)
 S = 1.431 (23.45 x 10³)

(1-5/16" INFILL)

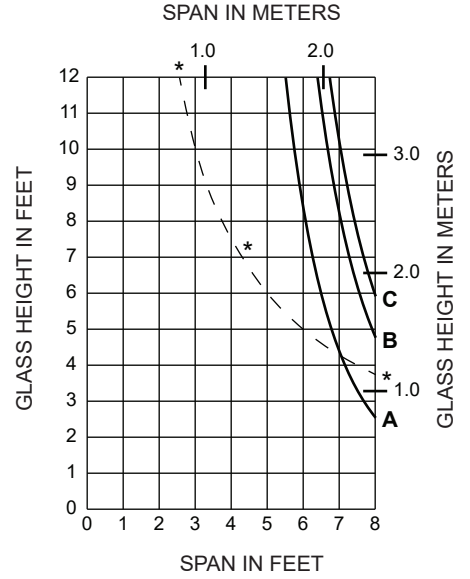

*** NOTE:**
 DASHED LINE REPRESENTS ALLOWABLE MAXIMUM GLASS LIMIT FOR A 4-1/2" LONG GLASS CHAIR. GLASS SIZES ABOVE THIS LINE REQUIRE THE GLASS CHAIR AND SETTING BLOCK TO BE DOUBLED UP (SIDE BY SIDE) AT POINTS REQUIRED.

(1" OR 1-1/4" INFILL)

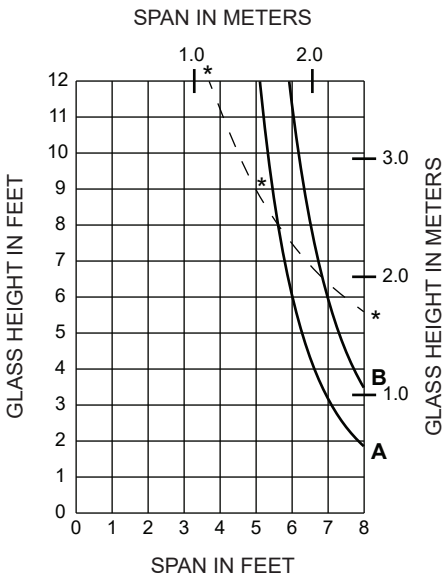

A = 1/4 POINT LOADING
B = 1/8 POINT LOADING
C = 1/10 POINT LOADING

NOTE: GLASS CHAIR CENTERLINE SHOULD NOT BE LESS THAN 6-1/2" (165.1) FROM EDGE OF GLASS.

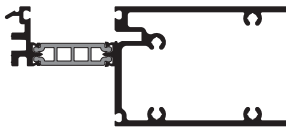

185227

I = 1.841 (76.63 x 10⁴)
 S = 1.431 (23.45 x 10³)

(1-5/16" INFILL)

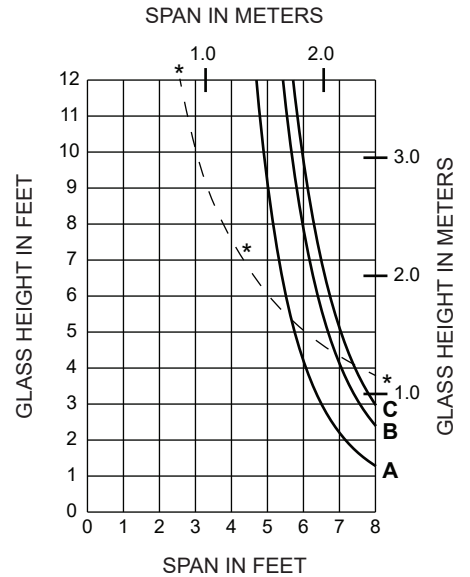

Laws and building and safety codes governing the design and use of Kawneer products, such as glazed entrance, window, and curtain wall products, vary widely. Kawneer does not control the selection of product configurations, operating hardware, or glazing materials, and assumes no responsibility therefor.

Kawneer reserves the right to change configuration without prior notice when deemed necessary for product improvement.
 © 2024, Kawneer Company, Inc.

(1" OR 1-1/4" INFILL)

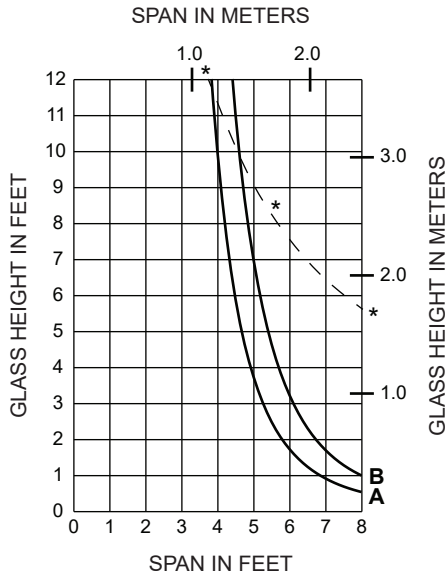

A = 1/4 POINT LOADING
B = 1/8 POINT LOADING

NOTE: GLASS CHAIR CENTERLINE SHOULD NOT BE LESS THAN 6-1/2" (165.1) FROM EDGE OF GLASS.

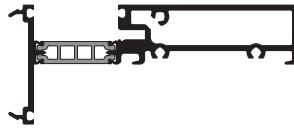

185229

I = 0.260 (10.82 x 10⁴)
S = 0.358 (5.87 x 10³)

(1-5/16" INFILL)

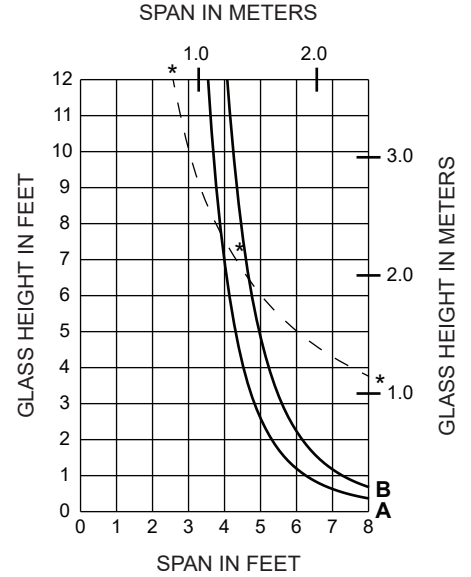

*** NOTE:**
DASHED LINE REPRESENTS ALLOWABLE MAXIMUM GLASS LIMIT FOR A 4-1/2" LONG GLASS CHAIR. GLASS SIZES ABOVE THIS LINE REQUIRE THE GLASS CHAIR AND SETTING BLOCK TO BE DOUBLED UP (SIDE BY SIDE) AT POINTS REQUIRED.

(1" OR 1-1/4" INFILL)

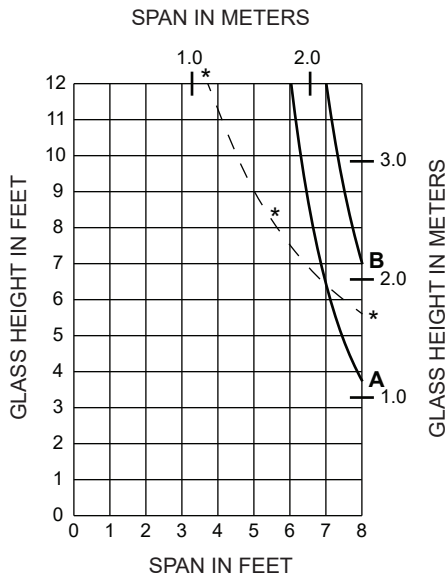

A = 1/4 POINT LOADING
B = 1/8 POINT LOADING
C = 1/10 POINT LOADING

NOTE: GLASS CHAIR CENTERLINE SHOULD NOT BE LESS THAN 6-1/2" (165.1) FROM EDGE OF GLASS.

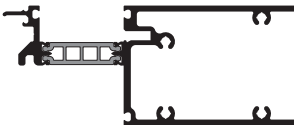

185249

I = 1.841 (76.63 x 10⁴)
S = 1.431 (23.45 x 10³)

(1-5/16" INFILL)

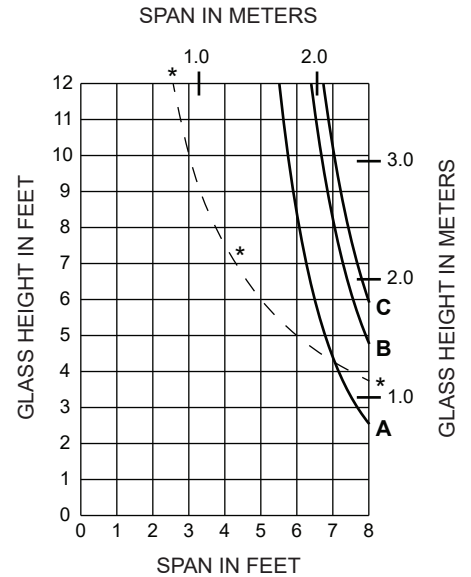

Laws and building and safety codes governing the design and use of Kawneer products, such as glazed entrance, window, and curtain wall products, vary widely. Kawneer does not control the selection of product configurations, operating hardware, or glazing materials, and assumes no responsibility therefor.

Kawneer reserves the right to change configuration without prior notice when deemed necessary for product improvement.
© 2024, Kawneer Company, Inc.

(1" OR 1-1/4" INFILL)

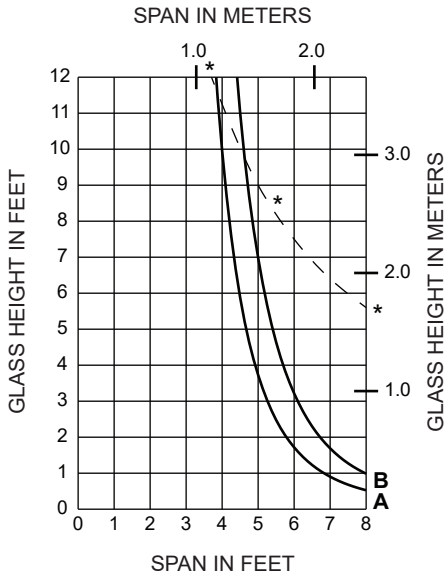

A = 1/4 POINT LOADING
B = 1/8 POINT LOADING

NOTE: GLASS CHAIR CENTERLINE SHOULD NOT BE LESS THAN 6-1/2" (165.1) FROM EDGE OF GLASS.

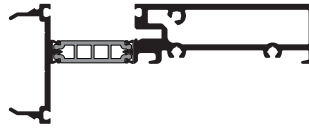

185251

I = 0.260 (10.82 x 10⁴)
S = 0.358 (5.87 x 10³)

(1-5/16" INFILL)

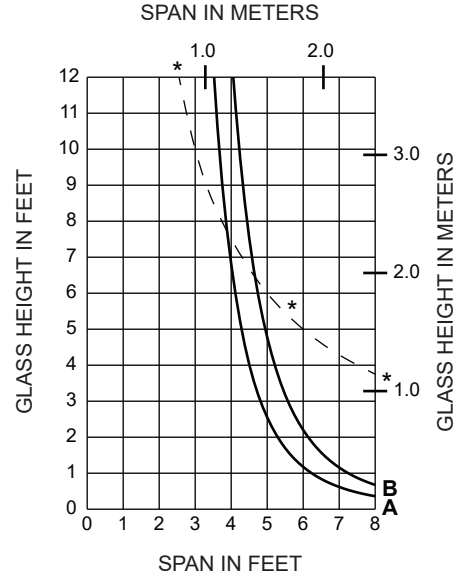

*** NOTE:**
DASHED LINE REPRESENTS ALLOWABLE MAXIMUM GLASS LIMIT FOR A 4-1/2" LONG GLASS CHAIR. GLASS SIZES ABOVE THIS LINE REQUIRE THE GLASS CHAIR AND SETTING BLOCK TO BE DOUBLED UP (SIDE BY SIDE) AT POINTS REQUIRED.

(1" OR 1-1/4" INFILL)

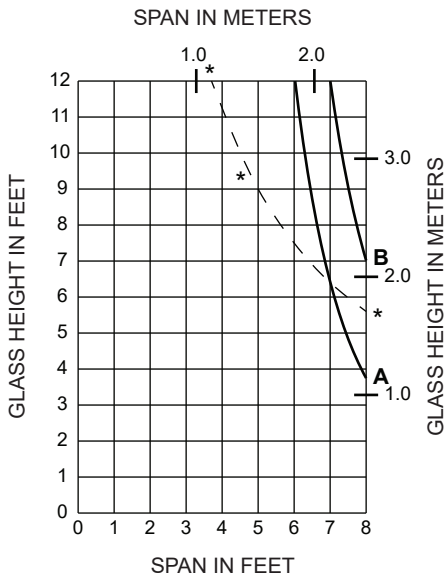

A = 1/4 POINT LOADING
B = 1/8 POINT LOADING
C = 1/10 POINT LOADING

NOTE: GLASS CHAIR CENTERLINE SHOULD NOT BE LESS THAN 6-1/2" (165.1) FROM EDGE OF GLASS.

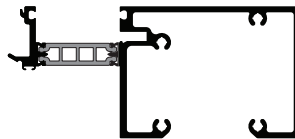

185258

I = 1.850 (77.00 x 10⁴)
S = 1.165 (19.09 x 10³)

(1-5/16" INFILL)

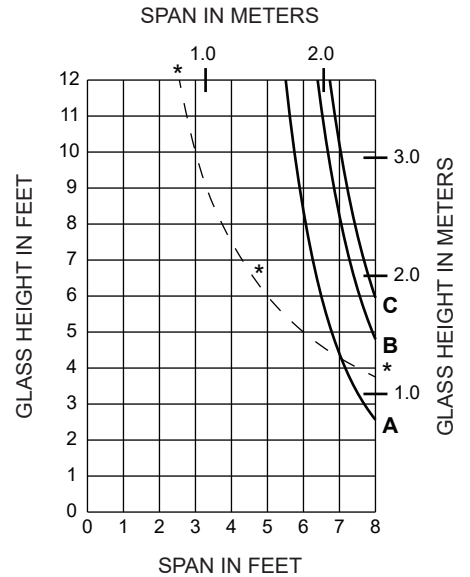

Laws and building and safety codes governing the design and use of Kawneer products, such as glazed entrance, window, and curtain wall products, vary widely. Kawneer does not control the selection of product configurations, operating hardware, or glazing materials, and assumes no responsibility therefor.

Kawneer reserves the right to change configuration without prior notice when deemed necessary for product improvement.
© 2024, Kawneer Company, Inc.

(1" OR 1-1/4" INFILL)

(1-5/16" INFILL)

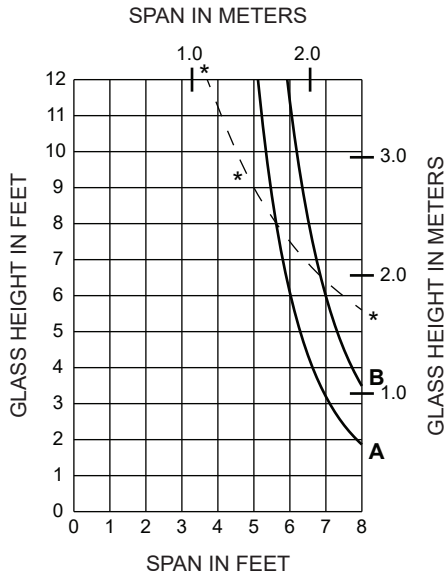

A = 1/4 POINT LOADING
 B = 1/8 POINT LOADING
 C = 1/10 POINT LOADING

NOTE: GLASS CHAIR CENTERLINE SHOULD NOT BE LESS THAN 6-1/2" (165.1) FROM EDGE OF GLASS.

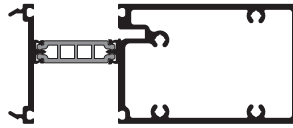

185276

I = 1.841 (76.63 x 10⁴)
 S = 1.431 (23.45 x 10³)

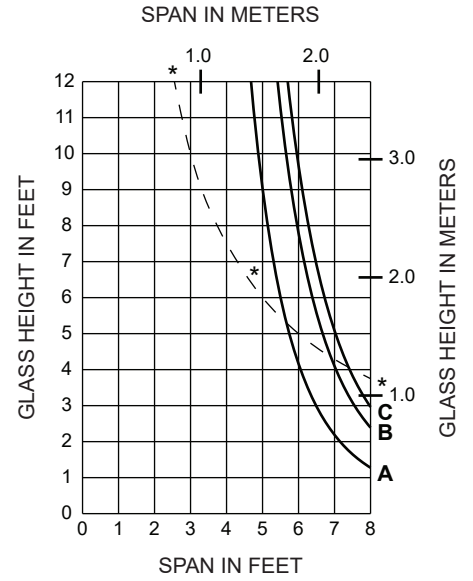

*** NOTE:**
 DASHED LINE REPRESENTS ALLOWABLE MAXIMUM GLASS LIMIT FOR A 4-1/2" LONG GLASS CHAIR. GLASS SIZES ABOVE THIS LINE REQUIRE THE GLASS CHAIR AND SETTING BLOCK TO BE DOUBLED UP (SIDE BY SIDE) AT POINTS REQUIRED.

Laws and building and safety codes governing the design and use of Kawneer products, such as glazed entrance, window, and curtain wall products, vary widely. Kawneer does not control the selection of product configurations, operating hardware, or glazing materials, and assumes no responsibility therefor.

Kawneer reserves the right to change configuration without prior notice when deemed necessary for product improvement.
 © 2024, Kawneer Company, Inc.

(1" OR 1-1/4" INFILL)

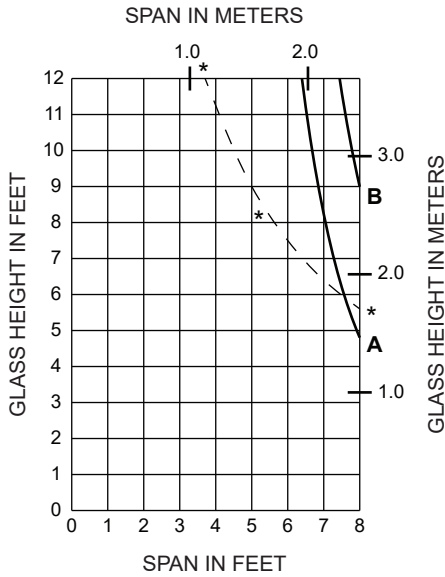

A = 1/4 POINT LOADING
B = 1/8 POINT LOADING
C = 1/10 POINT LOADING

NOTE: GLASS CHAIR CENTERLINE SHOULD NOT BE LESS THAN 6-1/2" (165.1) FROM EDGE OF GLASS.

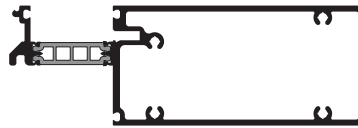

184224

$I = 2.371 (98.69 \times 10^4)$
 $S = 1.851 (30.33 \times 10^3)$

(1-5/16" INFILL)

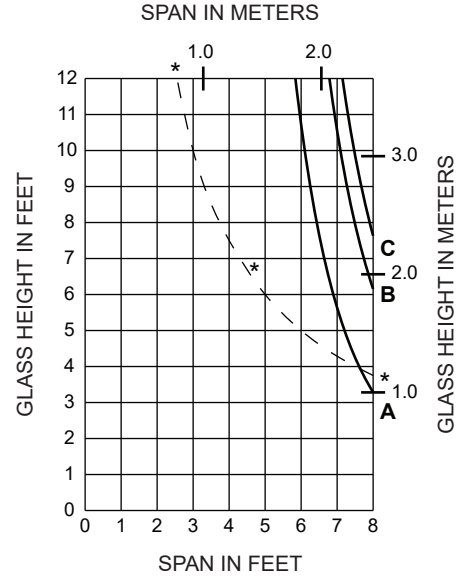

*** NOTE:**
 DASHED LINE REPRESENTS ALLOWABLE MAXIMUM GLASS LIMIT FOR A 4-1/2" LONG GLASS CHAIR. GLASS SIZES ABOVE THIS LINE REQUIRE THE GLASS CHAIR AND SETTING BLOCK TO BE DOUBLED UP (SIDE BY SIDE) AT POINTS REQUIRED.

(1" OR 1-1/4" INFILL)

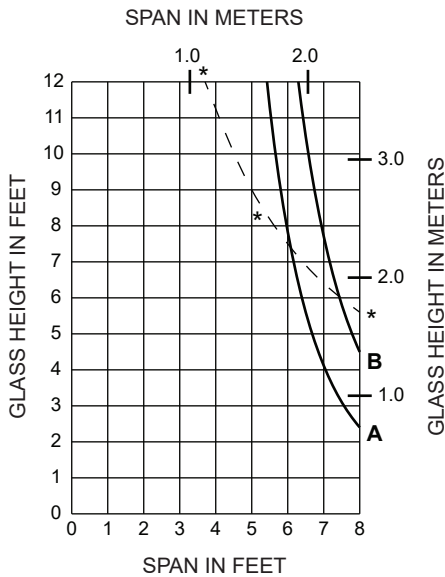

A = 1/4 POINT LOADING
B = 1/8 POINT LOADING
C = 1/10 POINT LOADING

NOTE: GLASS CHAIR CENTERLINE SHOULD NOT BE LESS THAN 6-1/2" (165.1) FROM EDGE OF GLASS.

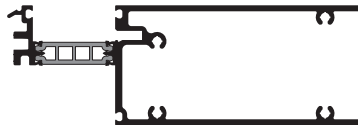

184227

$I = 2.371 (98.69 \times 10^4)$
 $S = 1.851 (30.33 \times 10^3)$

(1-5/16" INFILL)

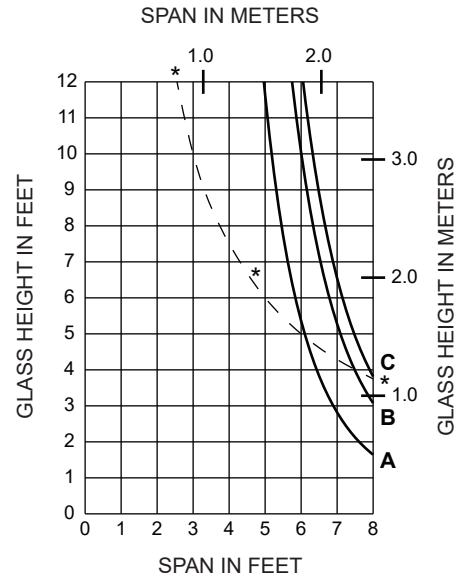

Laws and building and safety codes governing the design and use of Kawneer products, such as glazed entrance, window, and curtain wall products, vary widely. Kawneer does not control the selection of product configurations, operating hardware, or glazing materials, and assumes no responsibility therefor.

Kawneer reserves the right to change configuration without prior notice when deemed necessary for product improvement.
 © 2024, Kawneer Company, Inc.

(1" OR 1-1/4" INFILL)

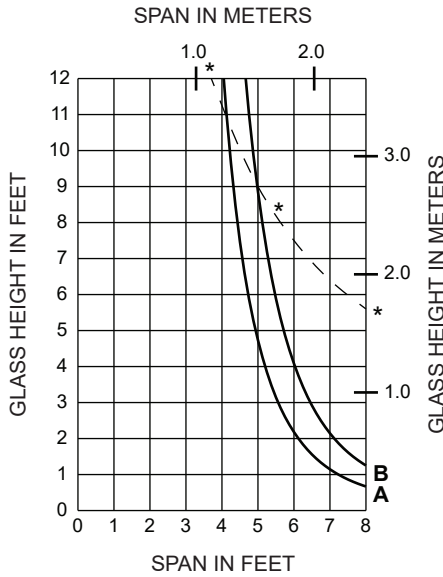

A = 1/4 POINT LOADING
B = 1/8 POINT LOADING

NOTE: GLASS CHAIR CENTERLINE SHOULD NOT BE LESS THAN 6-1/2" (165.1) FROM EDGE OF GLASS.



184229

I = 0.330 (13.74 x 10⁴)
S = 0.443 (7.26 x 10³)

(1-5/16" INFILL)

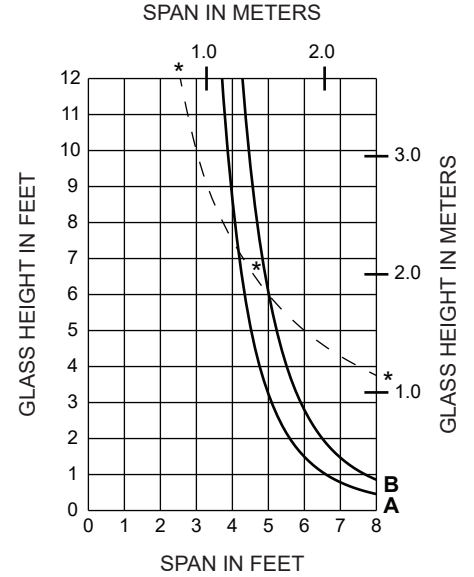

*** NOTE:**
DASHED LINE REPRESENTS ALLOWABLE MAXIMUM GLASS LIMIT FOR A 4-1/2" LONG GLASS CHAIR. GLASS SIZES ABOVE THIS LINE REQUIRE THE GLASS CHAIR AND SETTING BLOCK TO BE DOUBLED UP (SIDE BY SIDE) AT POINTS REQUIRED.

(1" OR 1-1/4" INFILL)

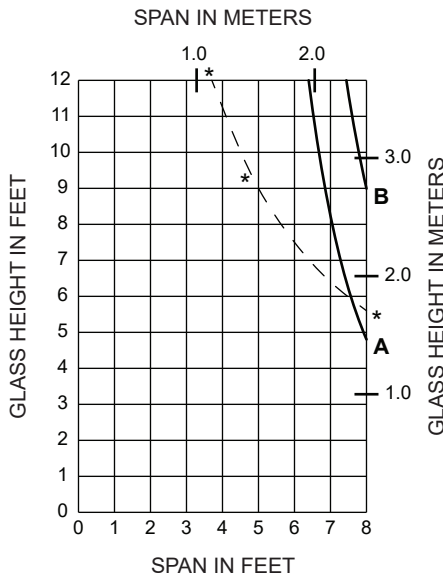

A = 1/4 POINT LOADING
B = 1/8 POINT LOADING
C = 1/10 POINT LOADING

NOTE: GLASS CHAIR CENTERLINE SHOULD NOT BE LESS THAN 6-1/2" (165.1) FROM EDGE OF GLASS.

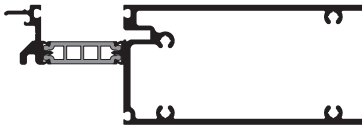

184249

I = 2.371 (98.69 x 10⁴)
S = 1.851 (30.33 x 10³)

(1-5/16" INFILL)

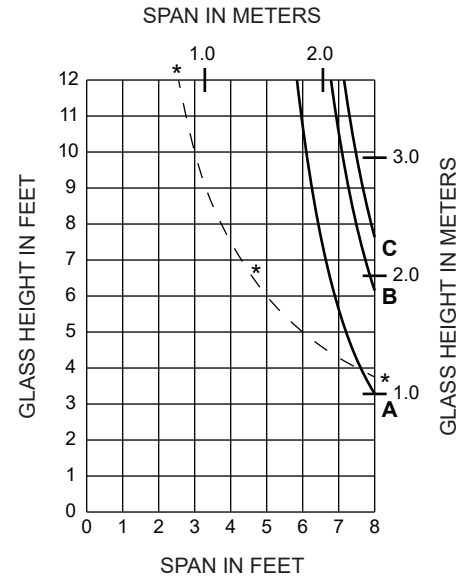

Laws and building and safety codes governing the design and use of Kawneer products, such as glazed entrance, window, and curtain wall products, vary widely. Kawneer does not control the selection of product configurations, operating hardware, or glazing materials, and assumes no responsibility therefor.

Kawneer reserves the right to change configuration without prior notice when deemed necessary for product improvement.
© 2024, Kawneer Company, Inc.

(1" OR 1-1/4" INFILL)

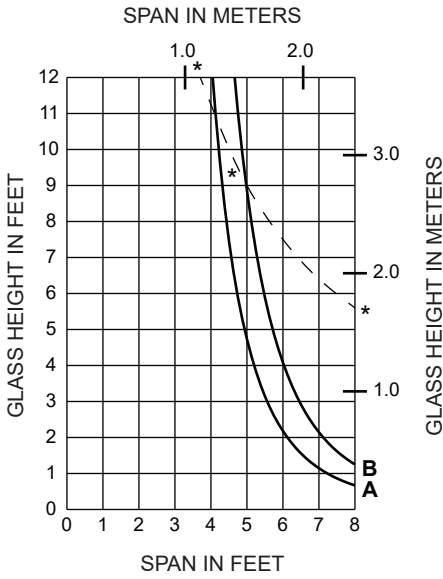

A = 1/4 POINT LOADING
B = 1/8 POINT LOADING

NOTE: GLASS CHAIR CENTERLINE SHOULD NOT BE LESS THAN 6-1/2" (165.1) FROM EDGE OF GLASS.



184251

I = 0.330 (13.74 x 10⁴)
S = 0.443 (7.26 x 10³)

(1-5/16" INFILL)

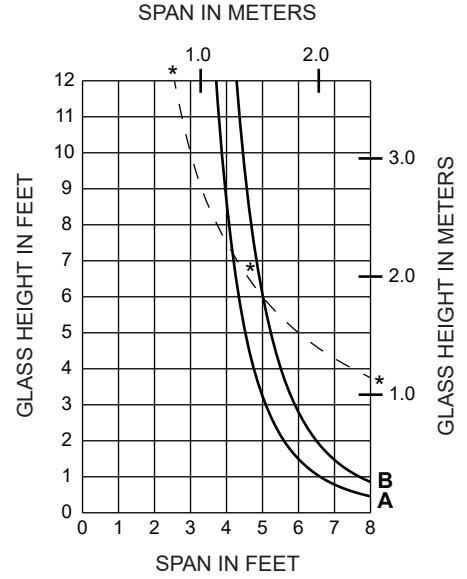

*** NOTE:**

DASHED LINE REPRESENTS ALLOWABLE MAXIMUM GLASS LIMIT FOR A 4-1/2" LONG GLASS CHAIR. GLASS SIZES ABOVE THIS LINE REQUIRE THE GLASS CHAIR AND SETTING BLOCK TO BE DOUBLED UP (SIDE BY SIDE) AT POINTS REQUIRED.

(1" OR 1-1/4" INFILL)

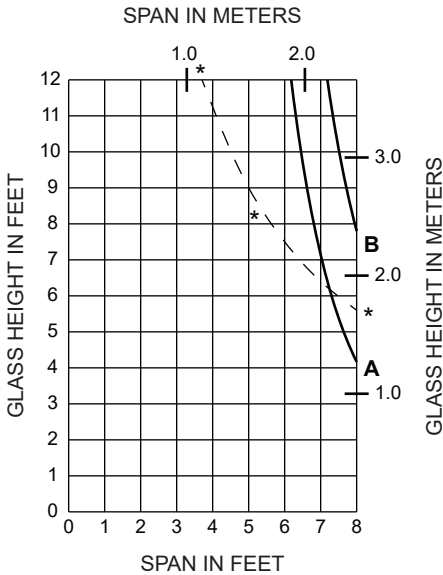

A = 1/4 POINT LOADING
B = 1/8 POINT LOADING
C = 1/10 POINT LOADING

NOTE: GLASS CHAIR CENTERLINE SHOULD NOT BE LESS THAN 6-1/2" (165.1) FROM EDGE OF GLASS.

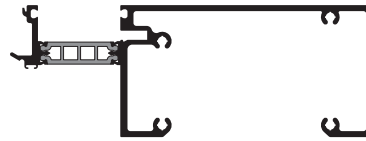

184258

I = 2.056 (85.58 x 10⁴)
S = 1.217 (19.94 x 10³)

(1-5/16" INFILL)

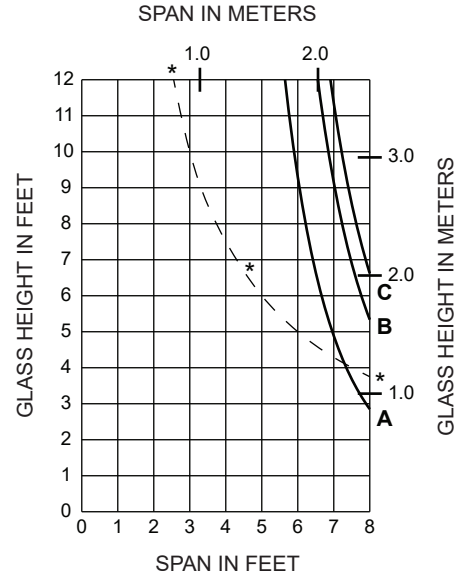

Laws and building and safety codes governing the design and use of Kawneer products, such as glazed entrance, window, and curtain wall products, vary widely. Kawneer does not control the selection of product configurations, operating hardware, or glazing materials, and assumes no responsibility therefor.

Kawneer reserves the right to change configuration without prior notice when deemed necessary for product improvement.
© 2024, Kawneer Company, Inc.

(1" OR 1-1/4" INFILL)

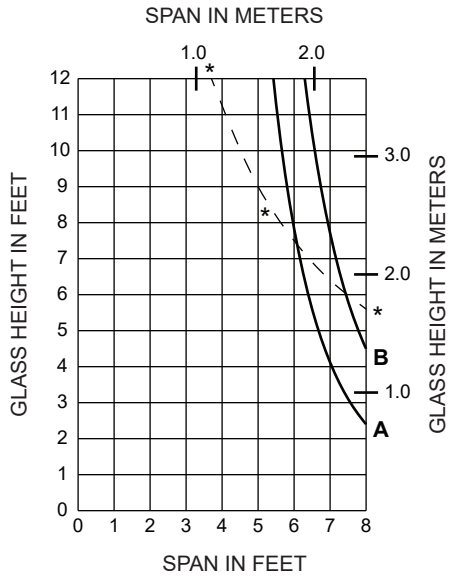

A = 1/4 POINT LOADING
 B = 1/8 POINT LOADING
 C = 1/10 POINT LOADING

NOTE: GLASS CHAIR CENTERLINE SHOULD NOT BE LESS THAN 6-1/2" (165.1) FROM EDGE OF GLASS.

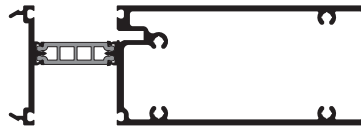

184276

I = 2.371 (98.69 x 10⁴)
 S = 1.851 (30.33 x 10³)

(1-5/16" INFILL)

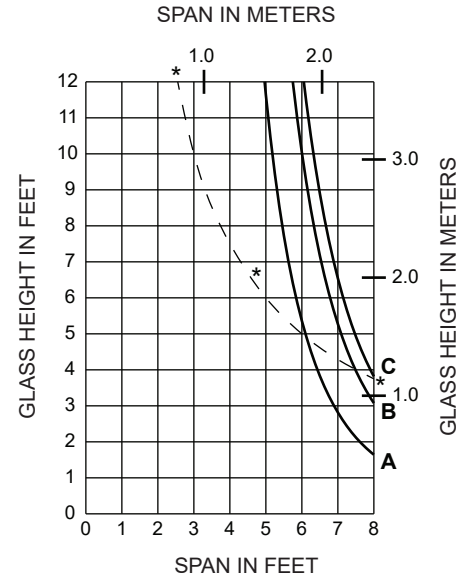

*** NOTE:**
 DASHED LINE REPRESENTS ALLOWABLE MAXIMUM GLASS LIMIT FOR A 4-1/2" LONG GLASS CHAIR. GLASS SIZES ABOVE THIS LINE REQUIRE THE GLASS CHAIR AND SETTING BLOCK TO BE DOUBLED UP (SIDE BY SIDE) AT POINTS REQUIRED.

Laws and building and safety codes governing the design and use of Kawneer products, such as glazed entrance, window, and curtain wall products, vary widely. Kawneer does not control the selection of product configurations, operating hardware, or glazing materials, and assumes no responsibility therefor.

Kawneer reserves the right to change configuration without prior notice when deemed necessary for product improvement.
 © 2024, Kawneer Company, Inc.

Generic Project Specific U-factor Example Calculation
(Percent of Glass will vary on specific products depending on sitelines)
(Based on single bay of Curtain Wall/Window Wall)

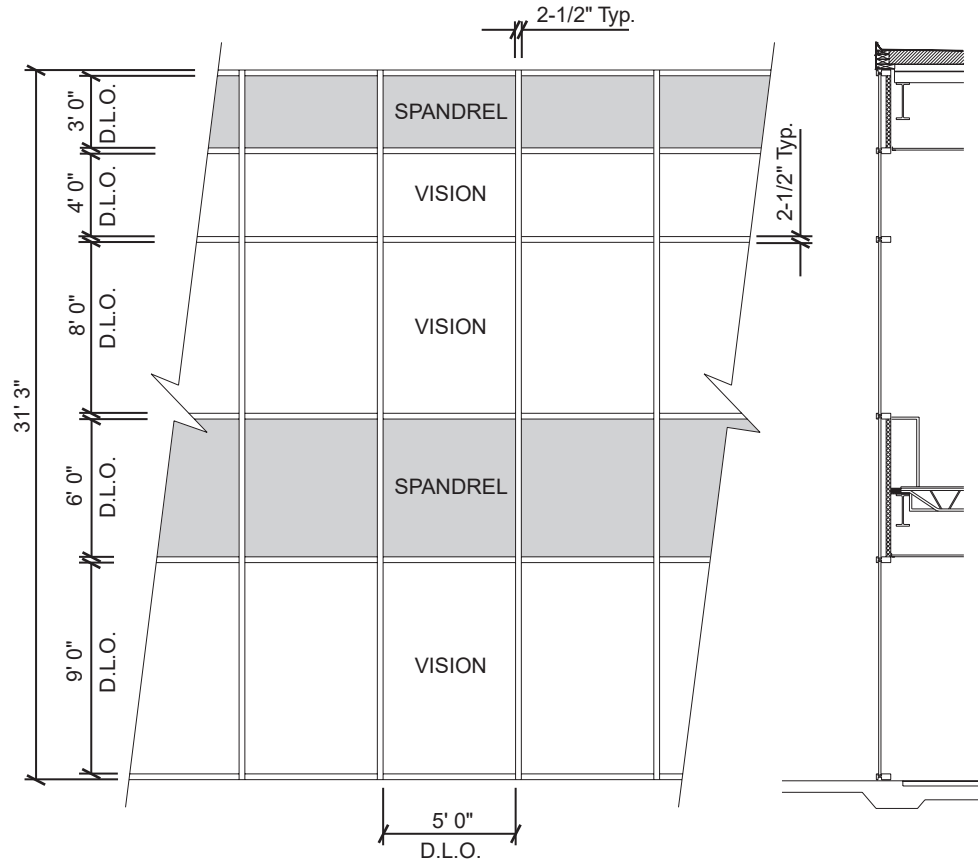

Vision Area

Example Glass U-factor	= 0.48 Btu/(ft ² · h · °F)
Vision Area	= 5(9 + 8 + 4) = 105.0 ft ²
Total Area (Vision)	= 5' 2-1/2" (9' 3-3/4" + 8' 2-1/2" + 4' 2-1/2") = 113.2 ft ²
Percentage of Vision Glass	= (Vision Area ÷ Total Area)100 = (105.0 ÷ 113.2)100 = 93%

Spandrel Area

Example Spandrel R-value	= 15 (ft ² · h · °F)/Btu
Spandrel Area	= 5(6 + 3) = 45.0 ft ²
Total Area (Spandrel)	= 5' 2-1/2" (6' 2-1/2" + 3' 3-3/4") = 49.6 ft ²
Percent of Spandrel	= (Spandrel Area ÷ Total Area)100 = (49.0 ÷ 49.6)100 = 91%

Laws and building and safety codes governing the design and use of Kawneer products, such as glazed entrance, window, and curtain wall products, vary widely. Kawneer does not control the selection of product configurations, operating hardware, or glazing materials, and assumes no responsibility therefor.

Kawneer reserves the right to change configuration without prior notice when deemed necessary for product improvement.
© 2024, Kawneer Company, Inc.

Vision Area Chart

Laws and building and safety codes governing the design and use of Kawneer products, such as glazed entrance, window, and curtain wall products, vary widely. Kawneer does not control the selection of product configurations, operating hardware, or glazing materials, and assumes no responsibility therefor.

Kawneer reserves the right to change configuration without prior notice when deemed necessary for product improvement.
© 2024, Kawneer Company, Inc.

System U-factor vs Percent of Vision Area

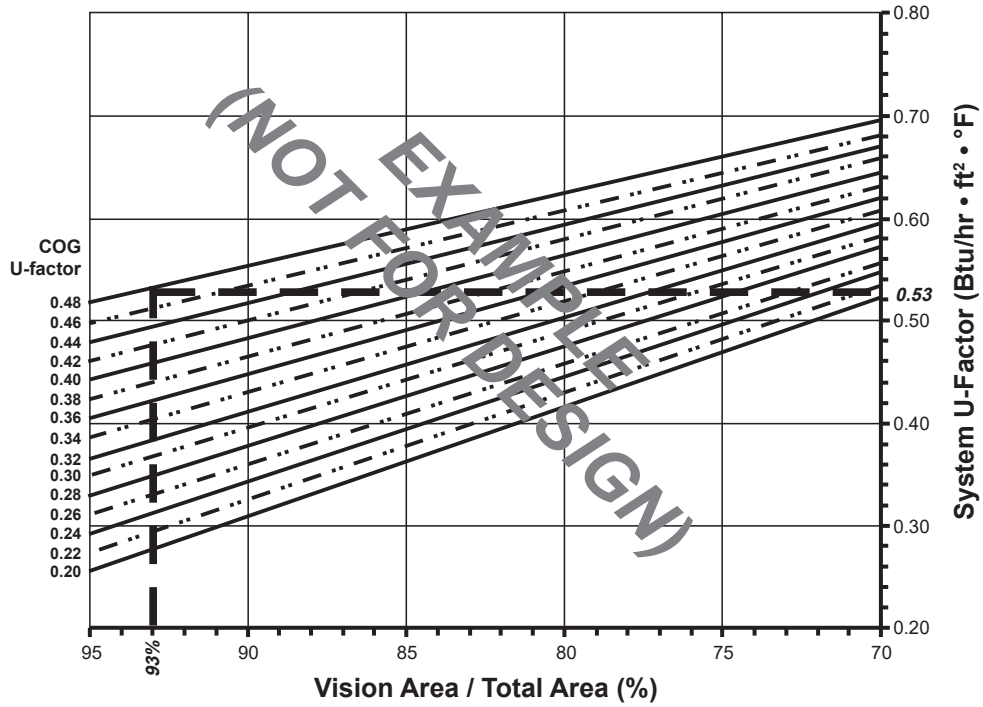

Based on a single curtain wall bay of 93% vision glass and center of glass U-factor of 0.48, System U-factor is equal to 0.53 Btu/(h·ft²·°F)

4 Side Captured
1" Double Glazed - Warm-Edge Glazing Spacer

Note:

Values in parentheses are metric.

COG = Center of Glass.

Charts are generated per AAMA 507

System U-Factor vs Percent of Glass Area

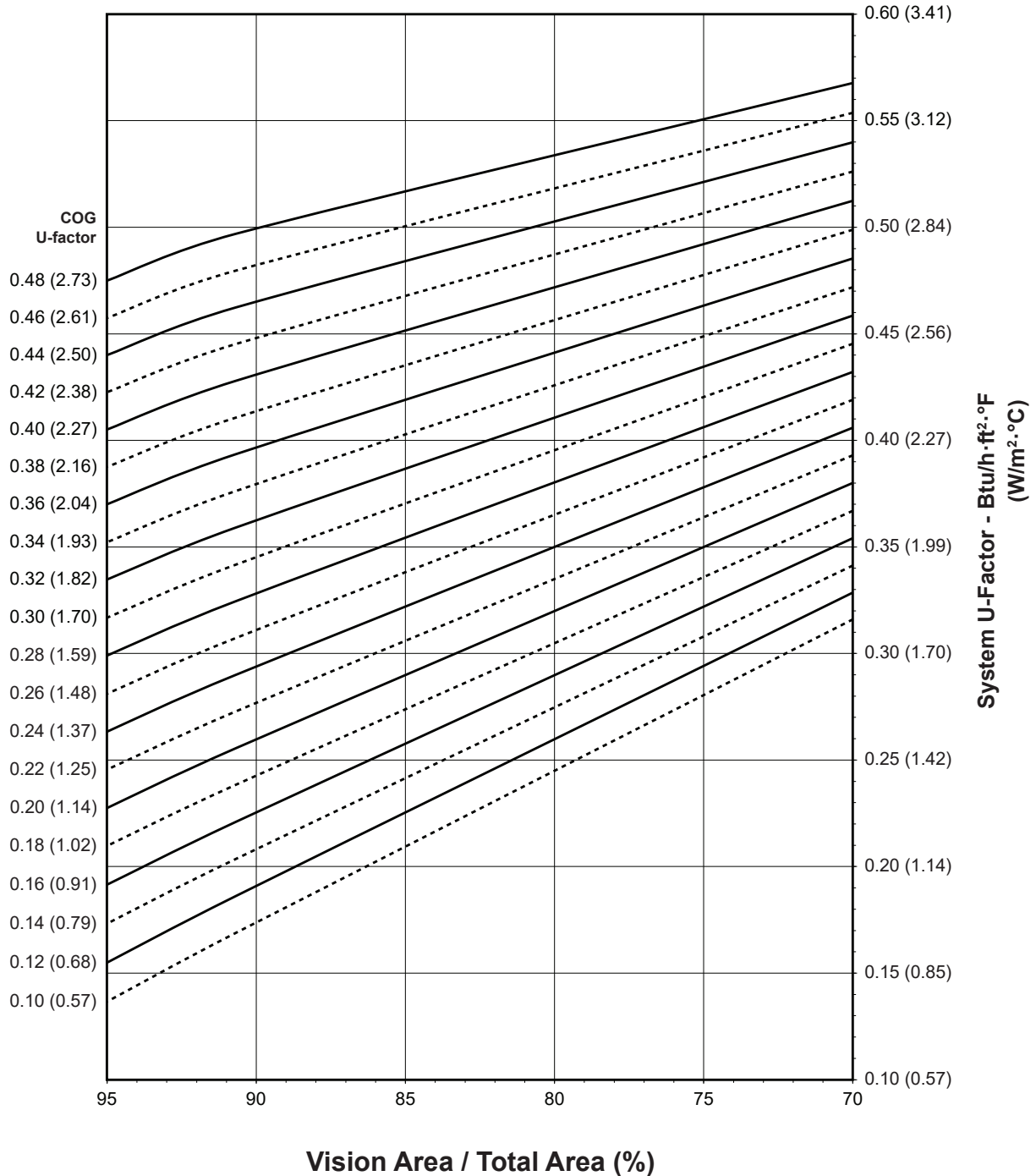

Notes for System U-factor, SHGC and VT charts:

For glass values that are not listed, linear interpolation is permitted.

Glass properties are based on center of glass values and are obtained from your glass supplier.

Laws and building and safety codes governing the design and use of Kawneer products, such as glazed entrance, window, and curtain wall products, vary widely. Kawneer does not control the selection of product configurations, operating hardware, or glazing materials, and assumes no responsibility therefor.

Kawneer reserves the right to change configuration without prior notice when deemed necessary for product improvement.

© 2024, Kawneer Company, Inc.

4 Side Captured 1" Double Glazed - Warm-Edge Glazing Spacer

System Solar Heat Gain Coefficient (SHGC) vs Percent of Vision Area

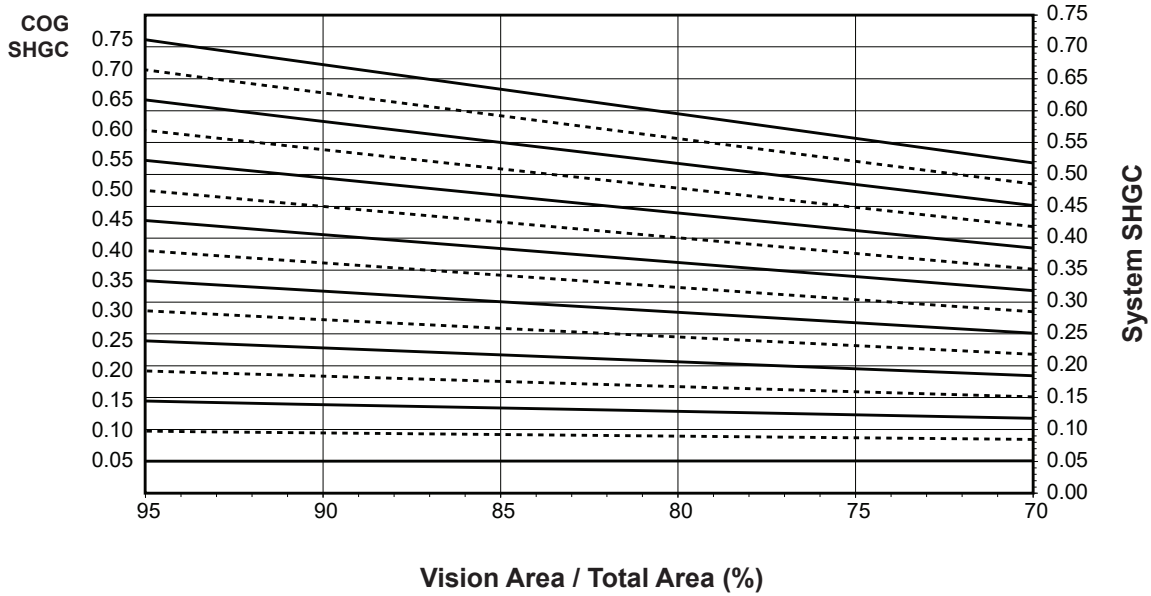

Charts are generated per AAMA 507

System Visible Transmittance (VT) vs Percent of Vision Area

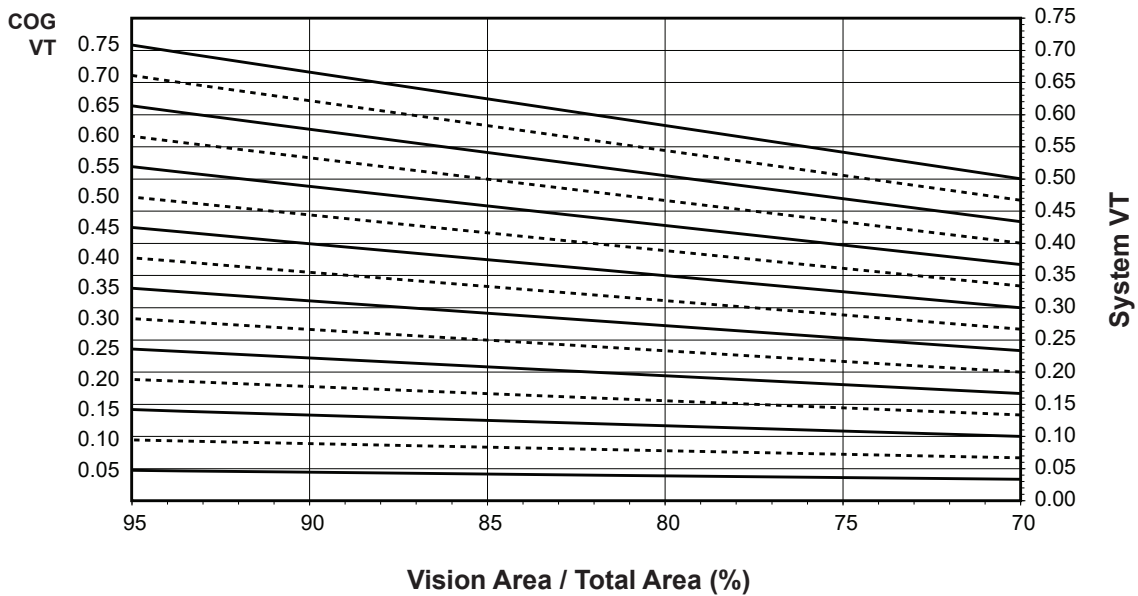

Laws and building and safety codes governing the design and use of Kawneer products, such as glazed entrance, window, and curtain wall products, vary widely. Kawneer does not control the selection of product configurations, operating hardware, or glazing materials, and assumes no responsibility therefor.

Kawneer reserves the right to change configuration without prior notice when deemed necessary for product improvement.
© 2024, Kawneer Company, Inc.

Thermal Transmittance¹ (BTU/hr • ft² • °F)

Glass U-Factor ³	Overall U-Factor ⁴
0.48	0.50
0.46	0.48
0.44	0.46
0.42	0.45
0.40	0.43
0.38	0.41
0.36	0.39
0.34	0.38
0.32	0.36
0.30	0.34
0.28	0.32
0.26	0.31
0.24	0.29
0.22	0.27
0.20	0.26
0.18	0.24
0.16	0.22
0.14	0.20
0.12	0.19
0.10	0.17

**4 Side Captured
1" Double Glazed
Warm-Edge Glazing Spacer**

NOTE: For glass values that are not listed, linear interpolation is permitted.

1. U-Factors are determined in accordance with NFRC 100.
2. SHGC and VT values are determined in accordance with NFRC 200.
3. Glass properties are based on center of glass values and are obtained from your glass supplier.
4. Overall U-Factor, SHGC, and VT Matricies are based on the standard NFRC specimen size of 2,000 mm wide by 2,000 mm high (78-3/4" by 78-3/4").

SHGC Matrix²

Glass SHGC ³	Overall SHGC ⁴
0.75	0.68
0.70	0.63
0.65	0.59
0.60	0.54
0.55	0.50
0.50	0.45
0.45	0.41
0.40	0.36
0.35	0.32
0.30	0.27
0.25	0.23
0.20	0.18
0.15	0.14
0.10	0.10
0.05	0.05

Visible Transmittance²

Glass VT ³	Overall VT ⁴
0.75	0.67
0.70	0.63
0.65	0.58
0.60	0.54
0.55	0.49
0.50	0.45
0.45	0.40
0.40	0.36
0.35	0.31
0.30	0.27
0.25	0.22
0.20	0.18
0.15	0.13
0.10	0.09
0.05	0.04

Laws and building and safety codes governing the design and use of Kawneer products, such as glazed entrance, window, and curtain wall products, vary widely. Kawneer does not control the selection of product configurations, operating hardware, or glazing materials, and assumes no responsibility therefor.

Kawneer reserves the right to change configuration without prior notice when deemed necessary for product improvement.
© 2024, Kawneer Company, Inc.

**4 Side Captured with Backer Rod Above Glass
1" Double Glazed - Warm-Edge Glazing Spacer - COG = 0.20**

Note:

Values in parentheses are metric.

COG = Center of Glass.

Charts are generated per AAMA 507

System U-Factor vs Percent of Glass Area

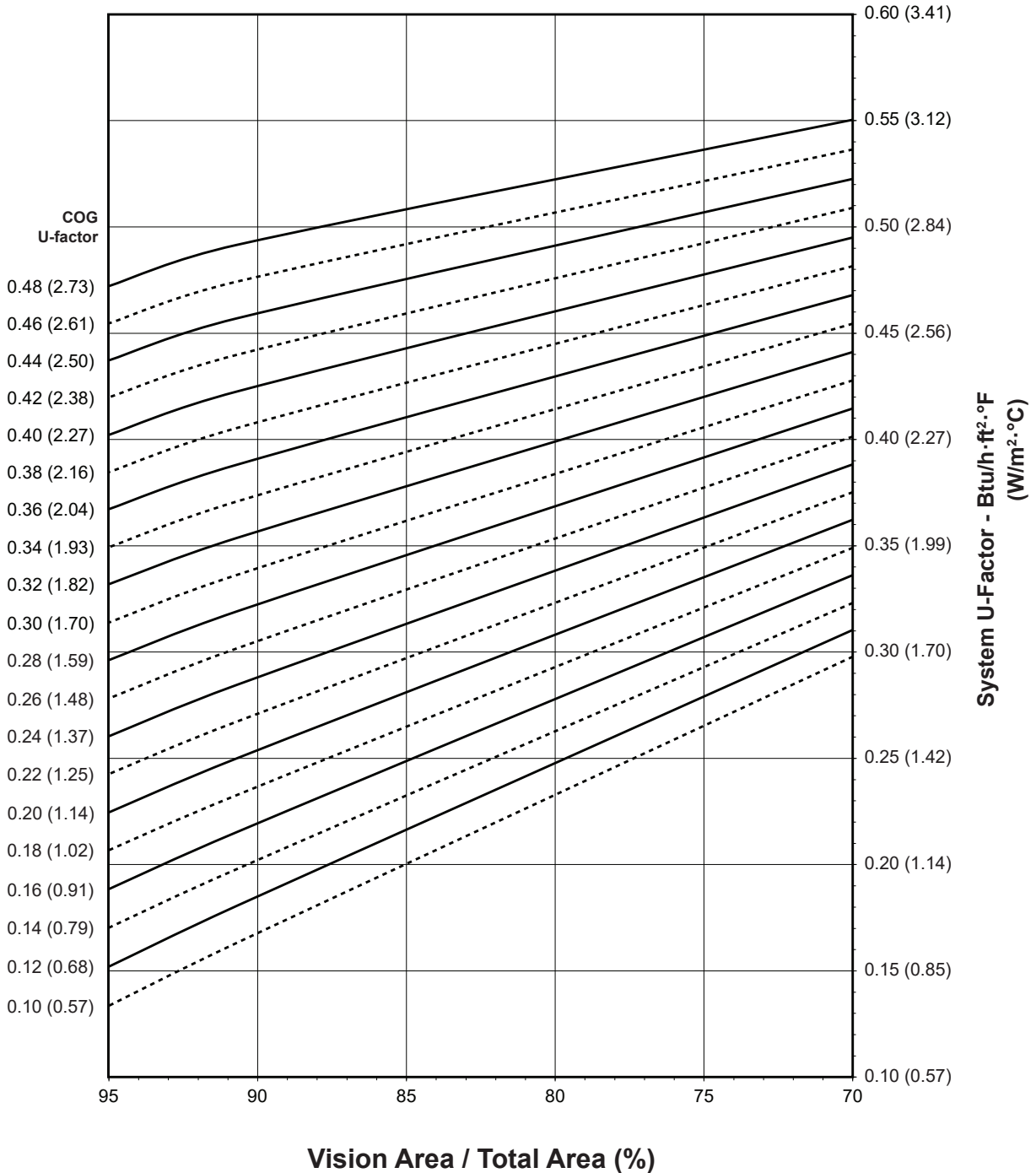

Laws and building and safety codes governing the design and use of Kawneer products, such as glazed entrance, window, and curtain wall products, vary widely. Kawneer does not control the selection of product configurations, operating hardware, or glazing materials, and assumes no responsibility therefor.

Kawneer reserves the right to change configuration without prior notice when deemed necessary for product improvement.
© 2024, Kawneer Company, Inc.

Notes for System U-factor, SHGC and VT charts:

For glass values that are not listed, linear interpolation is permitted.

Glass properties are based on center of glass values and are obtained from your glass supplier.

4 Side Captured with Backer Rod Above Glass 1" Double Glazed - Warm-Edge Glazing Spacer - COG = 0.20

System Solar Heat Gain Coefficient (SHGC) vs Percent of Vision Area

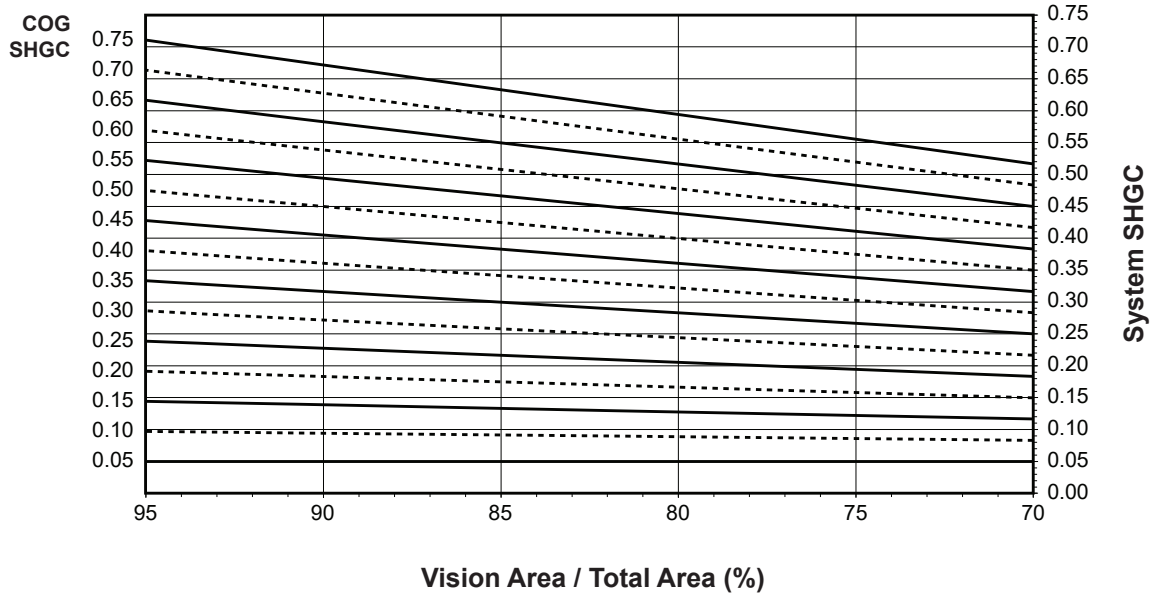

Charts are generated per AAMA 507

System Visible Transmittance (VT) vs Percent of Vision Area

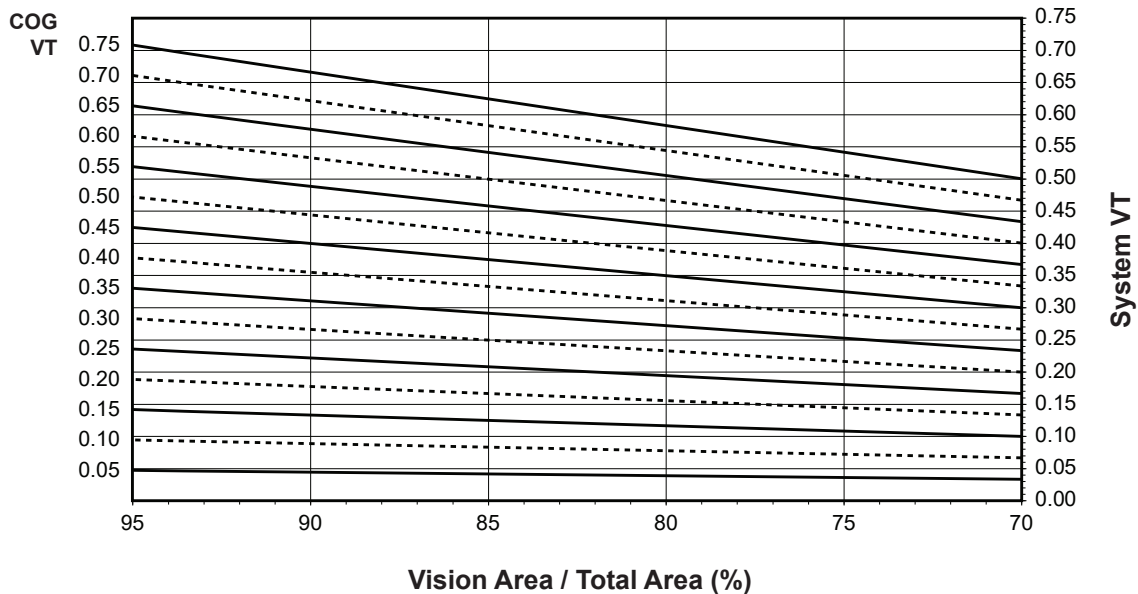

Laws and building and safety codes governing the design and use of Kawneer products, such as glazed entrance, window, and curtain wall products, vary widely. Kawneer does not control the selection of product configurations, operating hardware, or glazing materials, and assumes no responsibility therefor.

Kawneer reserves the right to change configuration without prior notice when deemed necessary for product improvement.
© 2024, Kawneer Company, Inc.

Thermal Transmittance ¹ (BTU/hr • ft ² • °F)

Glass U-Factor ³	Overall U-Factor ⁴
0.48	0.49
0.46	0.47
0.44	0.46
0.42	0.44
0.40	0.42
0.38	0.41
0.36	0.39
0.34	0.37
0.32	0.35
0.30	0.34
0.28	0.32
0.26	0.30
0.24	0.28
0.22	0.27
0.20	0.25
0.18	0.23
0.16	0.22
0.14	0.20
0.12	0.18
0.10	0.16

**4 Side Captured with
Backer Rod Above Glass
1" Double Glazed
Warm-Edge Glazing Spacer
COG = 0.20**

NOTE: For glass values that are not listed, linear interpolation is permitted.

1. U-Factors are determined in accordance with NFRC 100.
2. SHGC and VT values are determined in accordance with NFRC 200.
3. Glass properties are based on center of glass values and are obtained from your glass supplier.
4. Overall U-Factor, SHGC, and VT Matricies are based on the standard NFRC specimen size of 2,000 mm wide by 2,000 mm high (78-3/4" by 78-3/4").

SHGC Matrix ²

Glass SHGC ³	Overall SHGC ⁴
0.75	0.68
0.70	0.63
0.65	0.59
0.60	0.54
0.55	0.50
0.50	0.45
0.45	0.41
0.40	0.36
0.35	0.32
0.30	0.27
0.25	0.23
0.20	0.18
0.15	0.14
0.10	0.09
0.05	0.05

Visible Transmittance ²

Glass VT ³	Overall VT ⁴
0.75	0.67
0.70	0.63
0.65	0.58
0.60	0.54
0.55	0.49
0.50	0.45
0.45	0.40
0.40	0.36
0.35	0.31
0.30	0.27
0.25	0.22
0.20	0.18
0.15	0.13
0.10	0.09
0.05	0.04

Laws and building and safety codes governing the design and use of Kawneer products, such as glazed entrance, window, and curtain wall products, vary widely. Kawneer does not control the selection of product configurations, operating hardware, or glazing materials, and assumes no responsibility therefor.

Kawneer reserves the right to change configuration without prior notice when deemed necessary for product improvement.
© 2024, Kawneer Company, Inc.

Vertical SSG
1" Double Glazed - Warm-Edge Glazing Spacer

Note:

Values in parentheses are metric.
 COG = Center of Glass.
 Charts are generated per AAMA 507

System U-Factor vs Percent of Glass Area

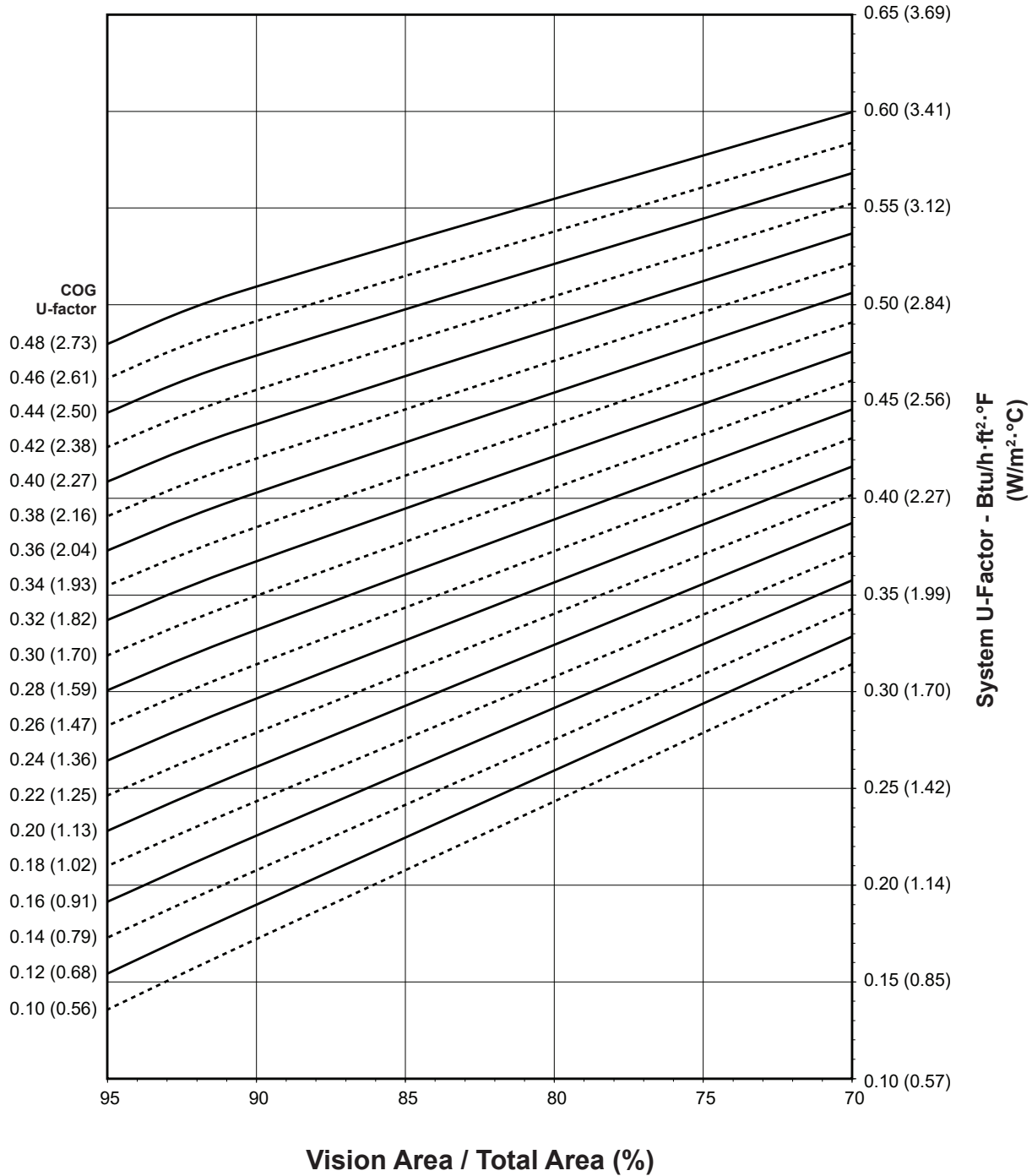

Notes for System U-factor, SHGC and VT charts:

For glass values that are not listed, linear interpolation is permitted.
 Glass properties are based on center of glass values and are obtained from your glass supplier.

Laws and building and safety codes governing the design and use of Kawneer products, such as glazed entrance, window, and curtain wall products, vary widely. Kawneer does not control the selection of product configurations, operating hardware, or glazing materials, and assumes no responsibility therefor.

Kawneer reserves the right to change configuration without prior notice when deemed necessary for product improvement.
 © 2024, Kawneer Company, Inc.

Vertical SSG
1" Double Glazed - Warm-Edge Glazing Spacer

System Solar Heat Gain Coefficient (SHGC) vs Percent of Vision Area

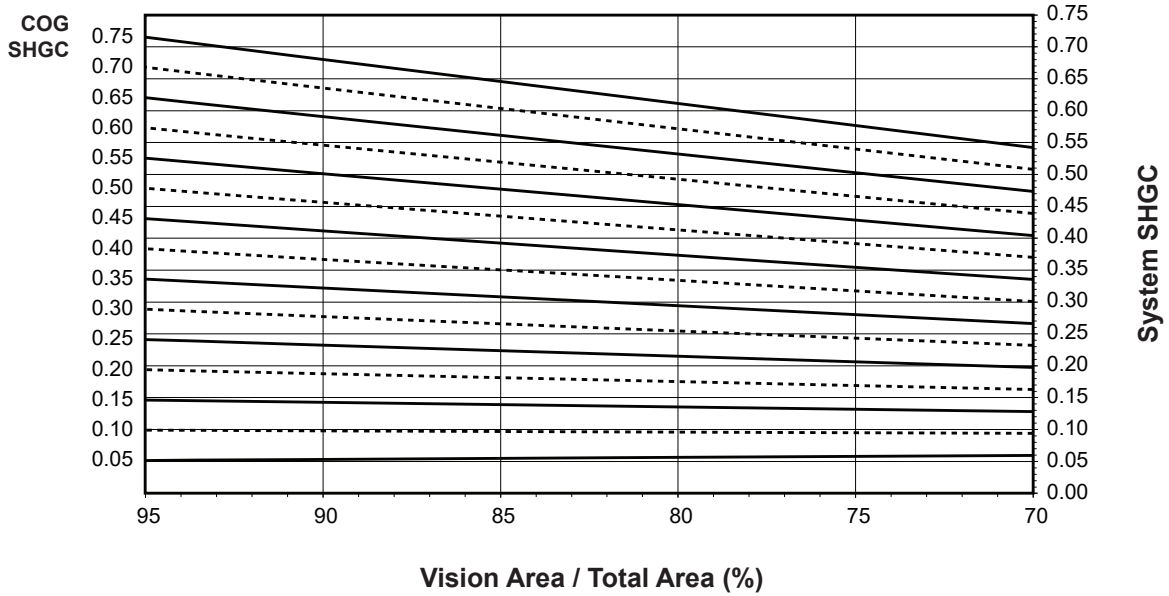

Charts are generated per AAMA 507

System Visible Transmittance (VT) vs Percent of Vision Area

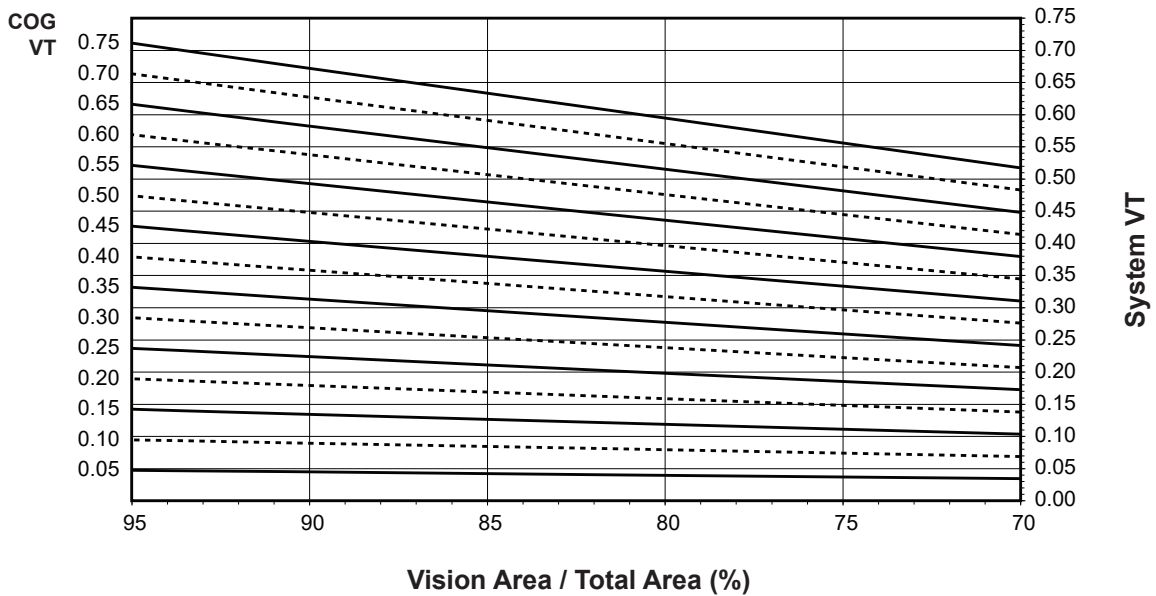

Laws and building and safety codes governing the design and use of Kawneer products, such as glazed entrance, window, and curtain wall products, vary widely. Kawneer does not control the selection of product configurations, operating hardware, or glazing materials, and assumes no responsibility therefor.

Kawneer reserves the right to change configuration without prior notice when deemed necessary for product improvement.
© 2024, Kawneer Company, Inc.

Thermal Transmittance ¹ (BTU/hr • ft² • °F)

Glass U-Factor ³	Overall U-Factor ⁴
0.48	0.51
0.46	0.49
0.44	0.47
0.42	0.45
0.40	0.43
0.38	0.42
0.36	0.40
0.34	0.38
0.32	0.36
0.30	0.35
0.28	0.33
0.26	0.31
0.24	0.29
0.22	0.27
0.20	0.26
0.18	0.24
0.16	0.22
0.14	0.20
0.12	0.19
0.10	0.17

**Vertical SSG
1" Double Glazed
Warm-Edge Glazing Spacer**

NOTE: For glass values that are not listed, linear interpolation is permitted.

1. U-Factors are determined in accordance with NFRC 100.
2. SHGC and VT values are determined in accordance with NFRC 200.
3. Glass properties are based on center of glass values and are obtained from your glass supplier.
4. Overall U-Factor, SHGC, and VT Matricies are based on the standard NFRC specimen size of 2,000 mm wide by 2,000 mm high (78-3/4" by 78-3/4").

SHGC Matrix ²

Glass SHGC ³	Overall SHGC ⁴
0.75	0.69
0.70	0.64
0.65	0.59
0.60	0.55
0.55	0.50
0.50	0.46
0.45	0.41
0.40	0.37
0.35	0.32
0.30	0.28
0.25	0.23
0.20	0.19
0.15	0.14
0.10	0.10
0.05	0.05

Visible Transmittance ²

Glass VT ³	Overall VT ⁴
0.75	0.68
0.70	0.63
0.65	0.59
0.60	0.54
0.55	0.50
0.50	0.45
0.45	0.41
0.40	0.36
0.35	0.32
0.30	0.27
0.25	0.23
0.20	0.18
0.15	0.14
0.10	0.09
0.05	0.05

Laws and building and safety codes governing the design and use of Kawneer products, such as glazed entrance, window, and curtain wall products, vary widely. Kawneer does not control the selection of product configurations, operating hardware, or glazing materials, and assumes no responsibility therefor.

Kawneer reserves the right to change configuration without prior notice when deemed necessary for product improvement.
© 2024, Kawneer Company, Inc.

Vertical SSG with Backer Rod Above Glass
1" Double Glazed - Warm-Edge Glazing Spacer - COG = 0.20

Note:

Values in parentheses are metric.
 COG = Center of Glass.
 Charts are generated per AAMA 507

System U-Factor vs Percent of Glass Area

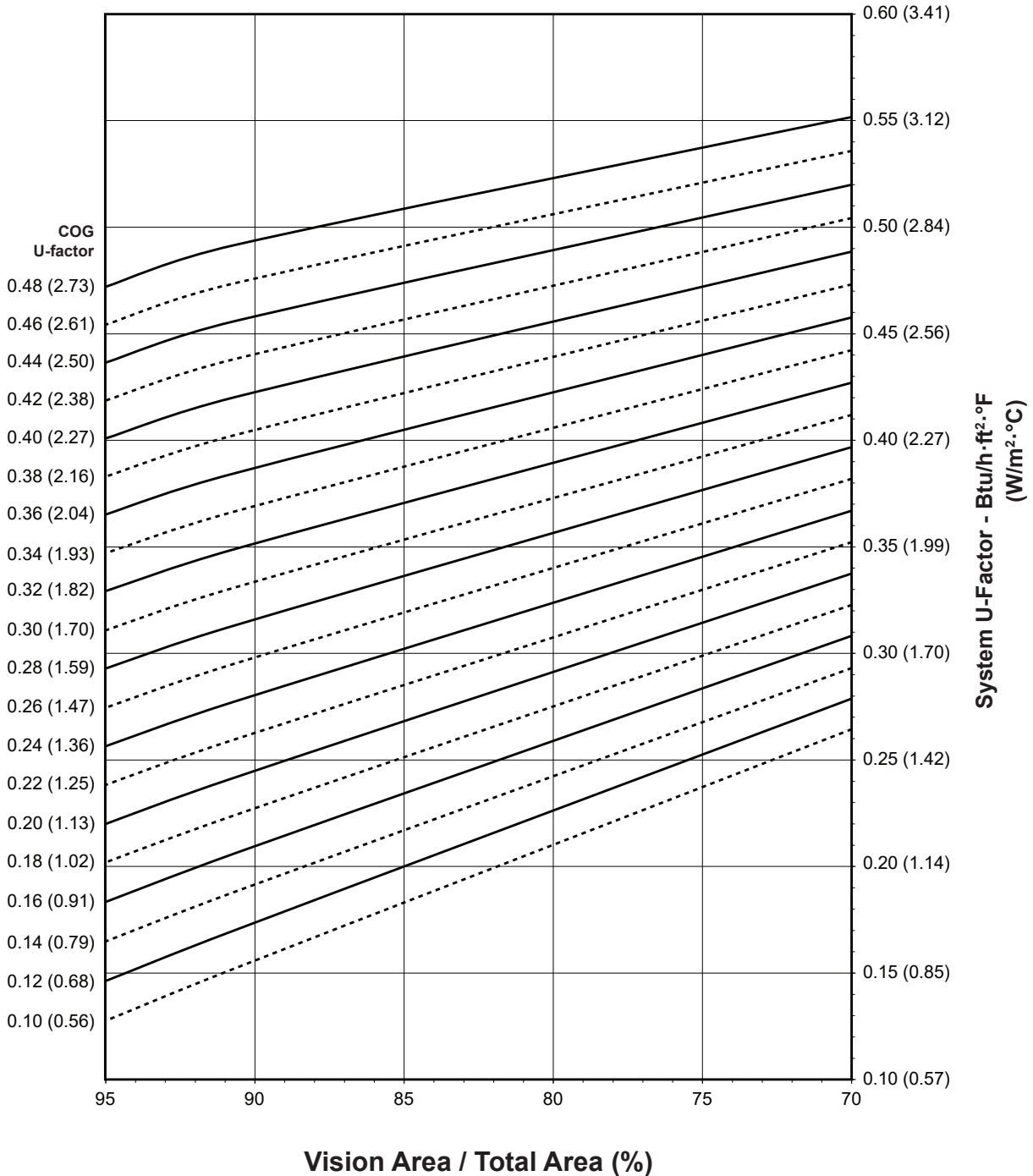

Notes for System U-factor, SHGC and VT charts:

For glass values that are not listed, linear interpolation is permitted.
 Glass properties are based on center of glass values and are obtained from your glass supplier.

Laws and building and safety codes governing the design and use of Kawneer products, such as glazed entrance, window, and curtain wall products, vary widely. Kawneer does not control the selection of product configurations, operating hardware, or glazing materials, and assumes no responsibility therefor.

Kawneer reserves the right to change configuration without prior notice when deemed necessary for product improvement.
 © 2024, Kawneer Company, Inc.

**Vertical SSG with Backer Rod Above Glass
1" Double Glazed - Warm-Edge Glazing Spacer - COG = 0.20**

System Solar Heat Gain Coefficient (SHGC) vs Percent of Vision Area

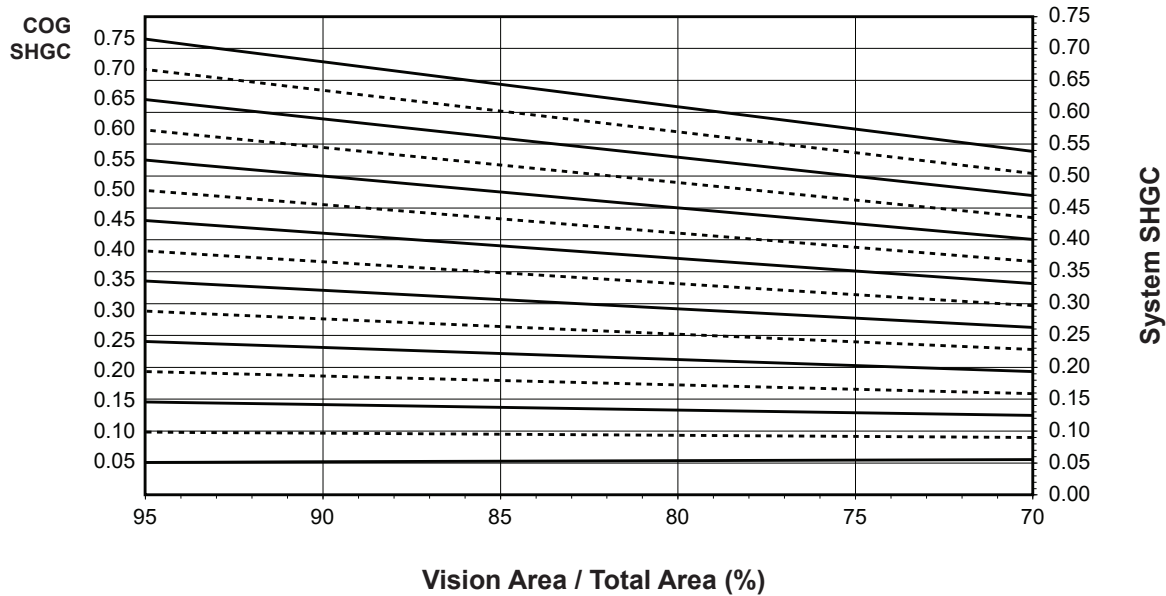

Charts are generated per AAMA 507

System Visible Transmittance (VT) vs Percent of Vision Area

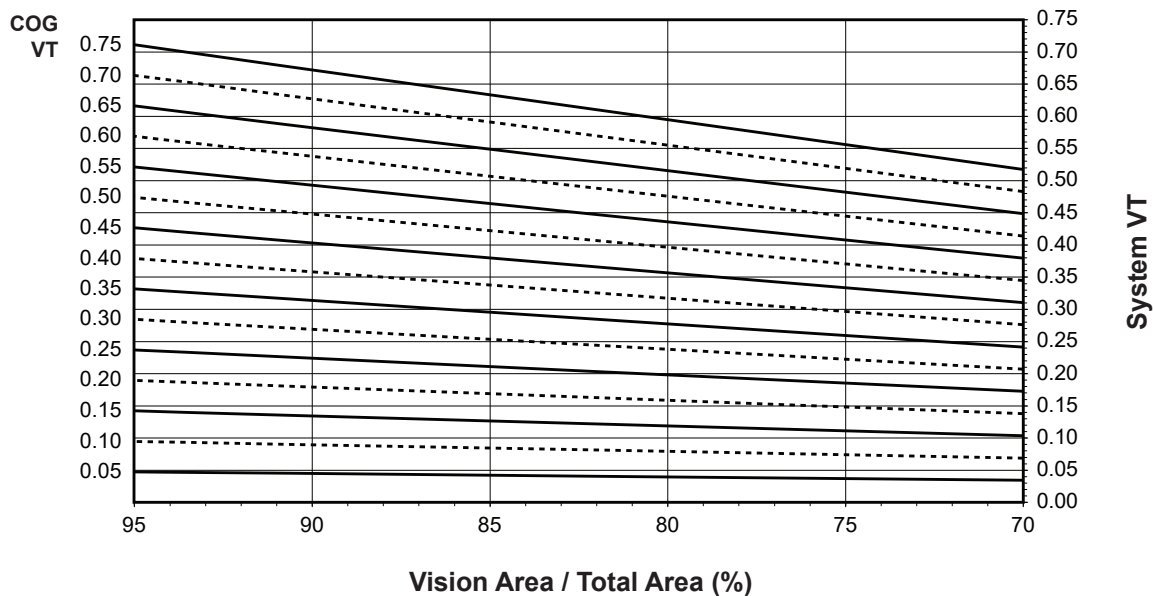

Laws and building and safety codes governing the design and use of Kawneer products, such as glazed entrance, window, and curtain wall products, vary widely. Kawneer does not control the selection of product configurations, operating hardware, or glazing materials, and assumes no responsibility therefor.

Kawneer reserves the right to change configuration without prior notice when deemed necessary for product improvement.
© 2024, Kawneer Company, Inc.

Thermal Transmittance ¹ (BTU/hr • ft ² • °F)

Glass U-Factor ³	Overall U-Factor ⁴
0.48	0.49
0.46	0.47
0.44	0.46
0.42	0.44
0.40	0.42
0.38	0.40
0.36	0.38
0.34	0.37
0.32	0.35
0.30	0.33
0.28	0.31
0.26	0.30
0.24	0.28
0.22	0.26
0.20	0.24
0.18	0.22
0.16	0.21
0.14	0.19
0.12	0.17
0.10	0.15

**Vertical SSG with
Backer Rod Above Glass
1" Double Glazed
Warm-Edge Glazing Spacer
COG = 0.20**

NOTE: For glass values that are not listed, linear interpolation is permitted.

1. U-Factors are determined in accordance with NFRC 100.
2. SHGC and VT values are determined in accordance with NFRC 200.
3. Glass properties are based on center of glass values and are obtained from your glass supplier.
4. Overall U-Factor, SHGC, and VT Matricies are based on the standard NFRC specimen size of 2,000 mm wide by 2,000 mm high (78-3/4" by 78-3/4").

SHGC Matrix ²

Glass SHGC ³	Overall SHGC ⁴
0.75	0.68
0.70	0.64
0.65	0.59
0.60	0.55
0.55	0.50
0.50	0.46
0.45	0.41
0.40	0.37
0.35	0.32
0.30	0.28
0.25	0.23
0.20	0.19
0.15	0.14
0.10	0.10
0.05	0.05

Visible Transmittance ²

Glass VT ³	Overall VT ⁴
0.75	0.68
0.70	0.63
0.65	0.59
0.60	0.54
0.55	0.50
0.50	0.45
0.45	0.41
0.40	0.36
0.35	0.32
0.30	0.27
0.25	0.23
0.20	0.18
0.15	0.14
0.10	0.09
0.05	0.05

Laws and building and safety codes governing the design and use of Kawneer products, such as glazed entrance, window, and curtain wall products, vary widely. Kawneer does not control the selection of product configurations, operating hardware, or glazing materials, and assumes no responsibility therefor.

Kawneer reserves the right to change configuration without prior notice when deemed necessary for product improvement.
© 2024, Kawneer Company, Inc.

Laws and building and safety codes governing the design and use of Kawneer products, such as glazed entrance, window, and curtain wall products, vary widely. Kawneer does not control the selection of product configurations, operating hardware, or glazing materials, and assumes no responsibility therefor.

Kawneer reserves the right to change configuration without prior notice when deemed necessary for product improvement.
© 2024, Kawneer Company, Inc.